

# Технические характеристики

## По вопросам продаж и поддержки обращайтесь:

Алматы (7273)495-231	Казань (843)206-01-48	Новокузнецк (3843)20-46-81	Смоленск (4812)29-41-54
Архангельск (8182)63-90-72	Калининград (4012)72-03-81	Новосибирск (383)227-86-73	Сочи (862)225-72-31
Астрахань (8512)99-46-04	Калуга (4842)92-23-67	Омск (3812)21-46-40	Ставрополь (8652)20-65-13
Барнаул (3852)73-04-60	Кемерово (3842)65-04-62	Орел (4862)44-53-42	Сургут (3462)77-98-35
Белгород (4722)40-23-64	Киров (8332)68-02-04	Оренбург (3532)37-68-04	Тверь (4822)63-31-35
Брянск (4832)59-03-52	Краснодар (861)203-40-90	Пенза (8412)22-31-16	Томск (3822)98-41-53
Владивосток (423)249-28-31	Красноярск (391)204-63-61	Пермь (342)205-81-47	Тула (4872)74-02-29
Волгоград (844)278-03-48	Курск (4712)77-13-04	Ростов-на-Дону (863)308-18-15	Тюмень (3452)66-21-18
Вологда (8172)26-41-59	Липецк (4742)52-20-81	Рязань (4912)46-61-64	Ульяновск (8422)24-23-59
Воронеж (473)204-51-73	Магнитогорск (3519)55-03-13	Самара (846)206-03-16	Уфа (347)229-48-12
Екатеринбург (343)384-55-89	Москва (495)268-04-70	Санкт-Петербург (812)309-46-40	Хабаровск (4212)92-98-04
Иваново (4932)77-34-06	Мурманск (8152)59-64-93	Саратов (845)249-38-78	Челябинск (351)202-03-61
Ижевск (3412)26-03-58	Набережные Челны (8552)20-53-41	Севастополь (8692)22-31-93	Череповец (8202)49-02-64
Иркутск (395)279-98-46	Нижний Новгород (831)429-08-12	Симферополь (3652)67-13-56	Ярославль (4852)69-52-93
Россия (495)268-04-70	Киргизия (996)312-96-26-47	Казахстан (7172)727-132	

# DIFFUSION PUMPS FEATURES AND BENEFITS

Agilent has earned its position as the leading diffusion pump manufacturer in the world by listening to customer needs and by continuously improving the performance and reliability of our benchmark designs. Throughout our more than forty years of leadership in the industry, we have consistently produced pumps that provide the most efficient means of converting heat into pumping throughput. Our experience has allowed us to optimize the design of every element of the pump. As a result, Agilent diffusion pumps offer you the lowest cost of ownership available for many high vacuum-pumping applications.



## **Low Cost of Ownership**

By providing the highest throughput available per unit of power, reduced cooling water requirements, and rugged, durable construction, Agilent delivers large volume pumping at the lowest total cost to you.



## **World-class Service, Training and Support**

Agilent's application consulting capability makes use of our unparalleled experience to identify the optimal solution for you. And we invite you to take advantage of our industry leading worldwide service and support programs and award winning vacuum training classes to maximize system uptime and productivity.



## **Options to Address Your Needs**

Many applications have unique requirements. Agilent can provide additional features such as Halo or custom baffles to eliminate additional backstreaming, and a Quick Cool Coil option to accelerate system cycle times.

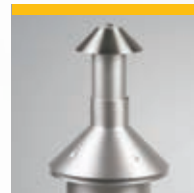

## **Fully Optimized Jet**

Using our long and varied experience Agilent designs and produces vapor jets that deliver the highest throughput, pressure stability, and tolerable foreline pressure available, while reducing backstreaming to a minimum.

# DIFFUSION PUMPS

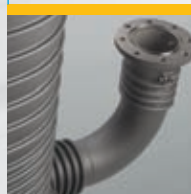

## Built for Production Volumes

Our success is in helping you meet the exacting requirements of your production process.

Our pumps deliver superior pumping at high pressure and high gas flow conditions, and handle gas load variations that are typical of large volume production.

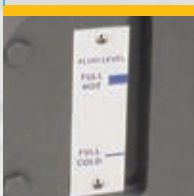

## Easy to Maintain

Maintaining uptime is critical so we have simplified operation and maintenance. A sight glass provides visual indication of status when cold or hot and under vacuum. A gauge port facilitates system troubleshooting.

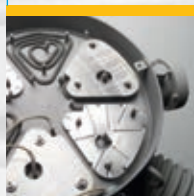

## Robust Boiler Design

Through optimized boiler design, Agilent pumps are stable and reliable under widely varying operating conditions.

This temperature stability prolongs fluid life as well.

Thermal protection switches prevent system over-temperature conditions.

## TYPICAL APPLICATIONS



*Courtesy of Mill Lane Engineering*

As the worldwide diffusion pump market leader, Agilent produces the most comprehensive family of pumps, ranging from 2 in. to 35 in. in diameter, and is the only broad-line, U.S.-based manufacturer.

The diffusion pump is the most common type of pump for use in high vacuum applications. These vapor jet pumps are one of the oldest and most reliable ways to create a vacuum. Since the chamber itself has no moving parts aside from the oil droplets, a vacuum diffusion pump can operate with stability over long periods.

In all diffusion pumps, a small amount of backstreaming occurs. Backstreaming is the migration of minute levels of oil that move in the opposite direction— toward the inlet of the pump and into the process stream, which may be the stage of an electron microscope or a welding chamber. In some applications, minor backstreaming has no impact; in others, where the purity of materials is critical, backstreaming cannot be tolerated. For this reason, systems typically add an optically dense baffle of varying design to deflect oil particles before they can reach the process stream.



*Courtesy of Materials Research Furnaces, Inc.*

Diffusion pumps are in wide use because they have several advantages: They are reliable, simple in design, operate without noise or vibration, and are relatively inexpensive to operate and maintain. In fact, diffusion pumping is still the most economical means of creating high-vacuum environments. These pumps also tolerate operating conditions such as excess particles and reactive gases that would destroy other types of high-vacuum pumps.

With the proper choice of motive fluids, traps, baffles, and valves, diffusion pumps can be used in a wide variety of applications and over pressure ranges from  $1 \times 10^{-3}$  Torr to  $2 \times 10^{-11}$  Torr

Key features of Agilent diffusion pumps include:

- High pumping speeds
- High throughput
- High forepressure tolerance
- Low ultimate pressure
- Excellent backstreaming characteristics
- Long-term reliability



# DIFFUSION PUMPS



## Vacuum Furnaces

Vacuum furnace applications require pumps that are capable of achieving stable pressures in high gas flow environments. Additionally, furnace operators need shorter cycle times to accomplish efficient processing of heat-treated material batches.

Furnace operators derive these benefits from Agilent vapor diffusion pumps, because the high throughput and low backstreaming rates of the pumps accommodate high material outgassing and allow higher cross-over pressures for shorter cycle times.

## Metallizing

In web and roll coating systems, Agilent diffusion pumps have the ability to pump high gas loads making them the perfect choice for continuous production applications.

## Large Area Coating/Thin Film Deposition

Due to its simplicity, high performance and low initial costs, the diffusion pump remains a primary pumping mechanism

for large area coating systems. The large pumps used in this application come equipped with sight glass and drain assemblies and are also available with ASA or ISO flanges.

## Coatings (Optical, Electronics, Protective)

With low ultimate pressure, high speed, high throughput and high tolerable forepressure, Agilent diffusion pumps are the best choice for developmental and production systems.

## Molecular Beams

The foreline ejector stage provides high tolerable forepressure and a large surface area for efficient degassing of compressed fluid, while the foreline baffle minimizes fluid loss even under high throughput conditions.

All Agilent pumps incorporate an ejector stage as well as full fractionating jets. HS series pumps create high speed and low ultimate pressure, high throughput and high tolerable forepressure and low backstreaming combine to make the HS series the best diffusion pump. Additionally, pumps are equipped with full thermal protection.

# PUMP SPECIFICATIONS

	AX-65	HS-2	VHS-4	VHS-6
Previous model number		<b>0160</b>	<b>0183</b>	<b>0184</b>
Pumping speed*, l/s (operating range)				
Air	65	160	750	1,550
Helium & hydrogen	90	200	940	1,930
Pumping speed AVS 4.1 (1963)*		285	1,200	2,400
Maximum forepressure, Torr (mbar)				
No load	0.75 (1.00)	0.55 (0.72)	0.65 (0.86)	0.65 (0.85)
Full load	0.60 (0.78)	0.40 (0.52)	0.55 (0.73)	0.55 (0.72)
Maximum throughput, T-l/s (mbar-l/s) In operating range @ 1 x 10 <sup>-2</sup> Torr (1.3 x 10 <sup>-2</sup> mbar)	0.19 (0.25) 0.30 (0.40)	0.60 (0.80) 0.70 (0.93)	1.5 (2.0) 2.5 (3.2)	2.4 (3.2) 3.5 (4.5)
Minimum recommended backing pump for maximum throughput, cfm (m <sup>3</sup> /hr)	0.15 (0.25)	5.0 (8.5)	10 (17)	17.0 (28.9)
Backstreaming rate at inlet flange mg/cm <sup>2</sup> /min (standard cold cap)*	2 x 10 <sup>-4</sup>	1 x 10 <sup>-3</sup>	5 x 10 <sup>-4</sup>	5 x 10 <sup>-4</sup>
Warmup time, minutes	7	15	10	10
Cooldown time, minutes with quick cool coil, where applicable	10	10	10	10
Fluid charge	30 cc	100 cc	300 cc	500 cc
Electrical requirements	1 ph 50/60 Hz 90/115/165/220 V	1 ph 50/60 Hz 120/240 V	1 ph 50/60 Hz 120/208/240 V	1 ph 50/60 Hz 120/208/240 V
Power, watts	200/250	450	1,45	2,2
Cooling water, U.S. gpm (l/hr) at 60-80 °F (15-26 °C)	N/A	0.1 (20)	0.15 (30)	0.25 (50)

\*For descriptions of pumping speed and backstreaming measurements, please see page 160.



# DIFFUSION PUMPS

VHS-250	VHS-10	VHS-400	HS-16	HS-20	HS-32	NHS-35
0178	0185	0182	0164	0165	0167	0169
2,125 2,660 3,700	3,650 4,560 5,300	4,500 5,625 8,000	6,000 7,500 10,000	10,000 12,500 17,500	17,300 21,625 32,000	28,000 35,000 50,000
0.65 (0.85) 0.55 (0.72)	0.65 (0.85) 0.55 (0.72)	0.65 (0.85) 0.55 (0.72)	0.65 (0.85) 0.55 (0.72)	0.65 (0.85) 0.55 (0.72)	0.50 (0.65) 0.35 (0.45)	0.55 (0.71) 0.40 (0.52)
2.6 (3.5) 3.5 (4.5)	6.3 (8.4) 7.5 (10.0)	6.3 (8.4) 7.5 (10.0)	9.5 (11.7) at 8100 W 11.5 (15.3) at 8100 W	12.5 (16.7) 18 (23.4)	30 (40) 35 (45.5)	25 (33) 35 (45.5)
17.0 (28.9)	30 (51)	30 (51)	80 (136)	100 (170)	300 (510)	300 (510)
$5 \times 10^{-4}$	$5 \times 10^{-4}$	$1 \times 10^{-3}$	$1.5 \times 10^{-3}$	$1.5 \times 10^{-3}$	$7 \times 10^{-4}$	$5 \times 10^{-4}$
10	15	15	30	45	60	60
10	25	25	30	45	60	60
500 cc	1,000 cc	1,000 cc	3 U.S. qts. (2.8 liters)	5 U.S. gal. (4.7 liters)	3 U.S. gal. (11.3 liters)	3 U.S. gal. (11.3 liters)
1 ph 50/60 Hz 120/208/240 V	3 ph 50/60 Hz 208/240/380/480 V	3 ph 50/60 Hz 208/240/380/480 V	3 ph 50/60 Hz 240/415/480 V	3 ph 50/60 Hz 240/415/480 V	3 ph 50/60 Hz 240/415/480 V	50/60 Hz 240/415/480 V
2.2	4.4	4.4	8,100/9,600	12	24	24
0.25 (50)	0.40 (80)	0.40 (80)	1.5 (300)	1.5 (300)	4.0 (800)	4.0 (800)

Diffusion Pumps



## PUMP MODELS

### ▶ Agilent AX-65

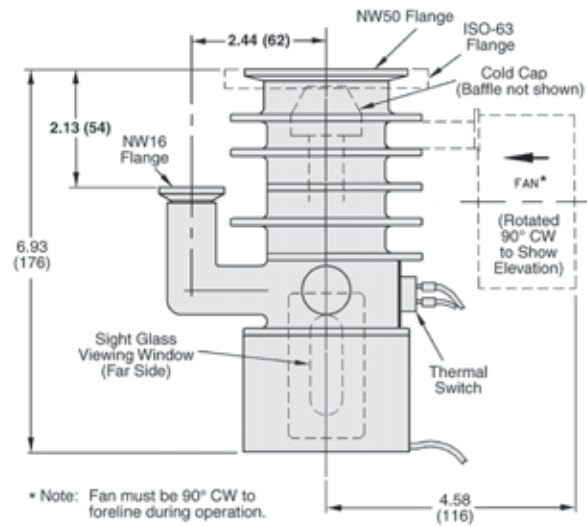

Dimensions: inches (millimeters)

### Technical Specifications

<b>Pumping speed*, operating range</b>	65 l/sec air, 90 l/s He and H <sub>2</sub>
<b>Maximum throughput</b>	0.19T-l/s (0.25 mbar-l/s) in operating range, 0.30T-l/s (0.40 mbar-l/s) @ 0.01 Torr
<b>Compression ratio</b>	4 x 10 <sup>7</sup> (air), 2 x 10 <sup>6</sup> (helium)
<b>Operating range</b>	3 x 10 <sup>-3</sup> to <5 x 10 <sup>-8</sup> Torr (3.9 x 10 <sup>-3</sup> to 6.5 x 10 <sup>-8</sup> mbar)
<b>Maximum forepressure</b>	No load: 0.75 Torr (1.00 mbar) Full load: 0.60 Torr (0.78 mbar)
<b>Backstreaming rate**</b>	With cold cap: <2 x 10 <sup>-4</sup> mg/cm <sup>2</sup> /min With baffle: <2 x 10 <sup>-5</sup> mg/cm <sup>2</sup> /min
<b>Recommended backing pump</b>	≥1.5 cfm (2.5 m <sup>3</sup> /hr)
<b>Warmup time</b>	7 minutes
<b>Cooldown time</b>	10 minutes
<b>Fluid charge</b>	30 cc
<b>Electrical requirements</b>	1 ph, 50/60 Hz, 90/115/165/220 VAC
<b>Pump power</b>	200/250 watts
<b>Air cooling</b>	30 cfm

\* For an explanation of pumping speed measurements, please see page 160.

\*\* Refer to page 158 for a description of test methods.



# DIFFUSION PUMPS

## AX-65 - Pumping Speed - Air/N<sub>2</sub>

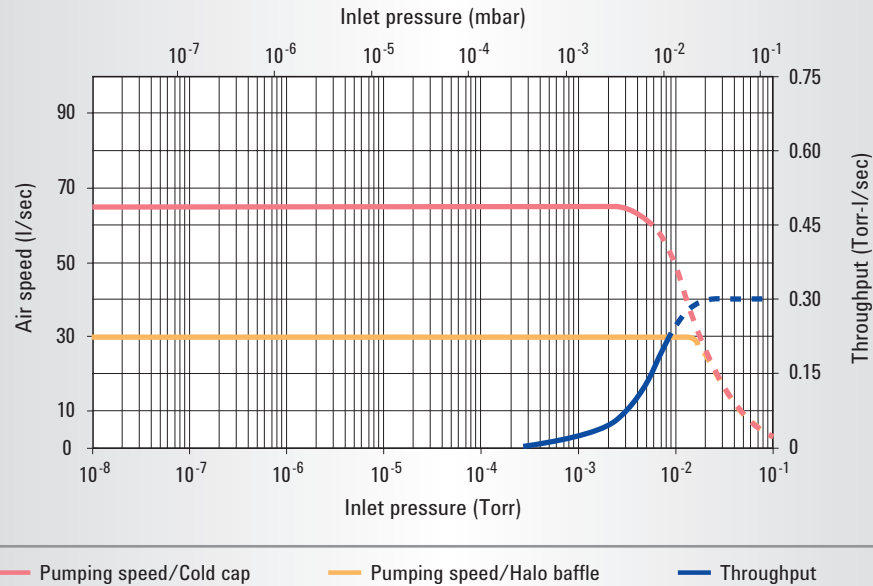

## Ordering Information

Description	Wt. kg (lbs)	Part Number	
		KF-50	ISO-6
AX-65 with standard cold cap, 115 V, 250 W	3.6 (8.0)	L9670301	L9707301
AX-65 with internal baffle, 115 V, 250 W	3.6 (8.0)	L9670311	L9707311
AX-65 with standard cold cap, 220 V, 250 W	3.6 (8.0)	L9670302	L9707302
AX-65 with internal baffle, 220 V, 250 W	3.6 (8.0)	L9670312	L9707312
AX-65 with standard cold cap, 115 V, 200 W	3.6 (8.0)	L9670303	L9707303
AX-65 with internal baffle, 115 V, 200 W	3.6 (8.0)	L9670313	L9707313
AX-65 with standard cold cap, 220 V, 200 W	3.6 (8.0)	L9670304	L9707304
AX-65 with internal baffle, 220 V, 200 W	3.6 (8.0)	L9670314	L9707314
AX-65 with standard cold cap, 90 V, 250 W	3.6 (8.0)	L9670305	L9707305
AX-65 with internal baffle, 90 V, 250 W	3.6 (8.0)	L9670315	L9707315
AX-65 with standard cold cap, 165 V, 250 W	3.6 (8.0)	L9670306	L9707306
AX-65 with internal baffle, 165 V, 250 W	3.6 (8.0)	L9670316	L9707316

- NOTE**
- All pumps have NW-16 foreline
  - See page 156 for Santovac 5 diffusion pump fluid
  - Mounted cooling fan included with each pump (P/N 661300138)
  - Overtemperature thermal switch set to open at 365 °F (182 °C)
  - Use 250W heater with polyphenyl ether fluids (such as Santovac 5). Use 200 W heater for other fluids.

Description	Wt. kg (lbs)	Part Number
<b>Accessories</b>		
Santovac 5 diffusion pump fluid, 40 cc	0.5 (1.0)	695405001
Santovac 5 diffusion dump fluid, 65 cc	0.9 (2.0)	695405002
Internal baffle kit	0.9 (2.0)	R1160065
Centering ring for inlet flange, NW50	0.5 (1.0)	KC50SB
Centering ring for inlet flange, ISO-63	0.2 (0.5)	IC063SV
Centering ring for foreline flange, NW16	0.2 (0.5)	KC16SB
Installation and Operation Manual		699901062

### Replacement Parts (one heater harness required per pump)

200 W, 115 V heater harness (for use with Invoil 704 or equivalent)	0.5 (1.0)	L9994307
250 W, 115 V heater harness (for use with Santovac 5 or equivalent)	0.5 (1.0)	L9994303
200 W, 220 V heater harness (for use with Invoil 704 or equivalent)	0.5 (1.0)	L9994308
250 W, 220 V heater harness (for use with Santovac 5 or equivalent)	0.5 (1.0)	L9994304
250 W, 90 V heater harness (for use with Santovac 5 or equivalent)	0.5 (1.0)	L9994301
250 W, 165 V heater harness (for use with Santovac 5 or equivalent)	0.5 (1.0)	L9994302
Overtemperature thermal switch (included with each heater harness)	0.5 (1.0)	L9964001
Pump ready thermal switch (optional)	0.5 (1.0)	L9964002

## PUMP MODELS

### ▶ Agilent HS-2

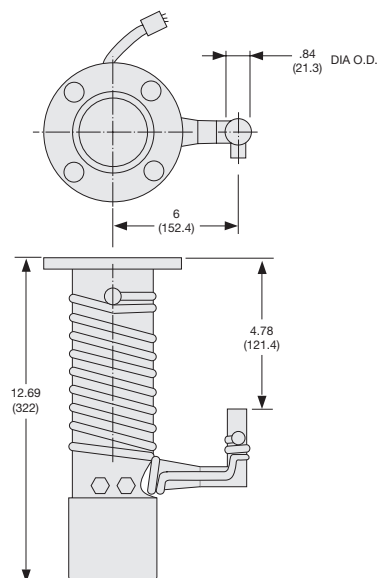

Dimensions: inches (millimeters)

### Technical Specifications

<b>Pumping speed, operating range</b>	160 l/s air, 200 l/s He and H <sub>2</sub>
<b>Pumping speed*, AVS 4.1 (1963)</b>	285 l/s air
<b>Maximum throughput</b>	0.60 T-l/s (0.80 mbar-l/s) in operating range, 0.70 T-l/s (0.93 mbar-l/s) @ 0.01 Torr
<b>Operating range</b>	$3.7 \times 10^{-3}$ to $< 5 \times 10^{-8}$ Torr, ( $4.9 \times 10^{-3}$ to $< 6.5 \times 10^{-8}$ mbar)
<b>Maximum forepressure</b>	No load: 0.55 Torr (0.71 mbar) Full load: 0.40 Torr (0.52 mbar)
<b>Recommended backing pump</b>	$\geq 5$ cfm (8.5 m <sup>3</sup> /hr)
<b>Backstreaming rate**, standard cold cap</b>	$< 1 \times 10^{-3}$ mg/cm <sup>2</sup> /min
<b>Warmup time</b>	15 minutes
<b>Cooldown time</b>	10 minutes (with quick cool coil)
<b>Fluid charge</b>	100 cc
<b>Electrical requirements</b>	1 ph, 50/60 Hz, 120/240 VAC
<b>Pump power</b>	450 watts
<b>Cooling water requirements</b>	0.1 gpm (20 l/hr) at 60-80 °F (15-26 °C)
<b>Water connections</b>	1/8 in. FPT

\* For an explanation of pumping speed measurements, please see page 160.

\*\* Refer to page 158 for a description of test methods.

# DIFFUSION PUMPS

## HS-2 Pumping Speed - Air/N<sub>2</sub>

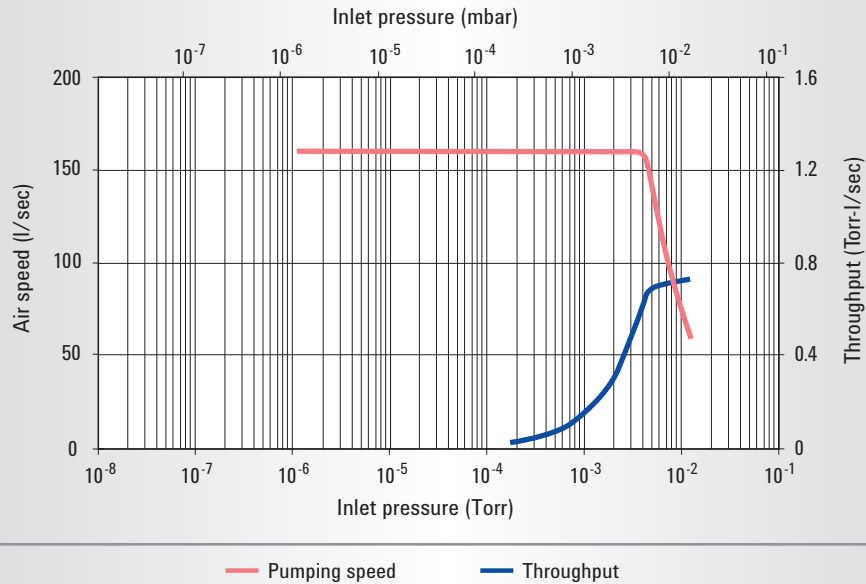

## Ordering Information

Description	Wt. kg (lbs)	Part Number
<b>ASA</b>		
With standard cold cap, 120 V	20.0 (9.0)	82906301
With standard cold cap, 240 V	20.0 (9.0)	82906302
Description	Wt. kg (lbs)	Part Number
Water-cooled baffle with ASA flanges	10.0 (4.5)	F9453302
Santovac 5 diffusion pump fluid, 500 cc pump fluid, 500 cc	2.5 (1.1)	695405005
Installation and Operation Manual		699901150

Description	Wt. kg (lbs)	Part Number
<b>Replacement Parts (one heater required per pump)</b>		
350 W, 120 V heater (HS2A)	1.0 (0.5)	647301100
350 W, 240 V heater (HS2A)	1.0 (0.5)	647301125
450 W, 120 V heater	1.0 (0.5)	647302125
450 W, 240 V heater	1.0 (0.5)	647302150
Heater block (one required per pump)	1.0 (0.5)	82920001
Heater platen (one required per pump)	1.0 (0.5)	82918301
Replacement o-ring kit, (5 Inlet flange o-rings (butyl 2-338))	1.0 (0.5)	K0377159

- NOTE**
- Inlet flange: nominal 2 in. ASA flange with 6 in. OD
  - Foreline flange: 0.84 in. diameter tube
  - See page 157 for baffles
  - See page 156 for santovac 5 diffusion pump fluid

## PUMP MODELS

### ▶ Agilent VHS-4

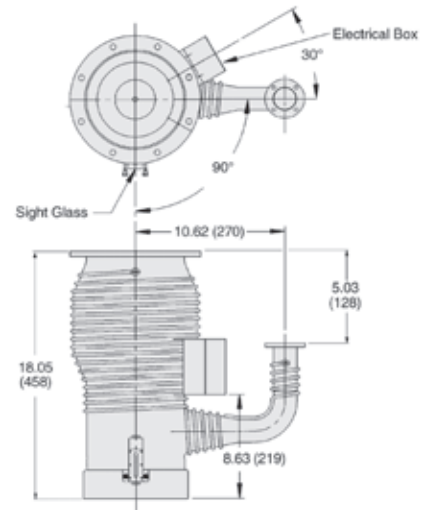

Dimensions: inches (millimeters)

### Technical Specifications

<b>Pumping speed*, operating range</b>	750 l/s air, 940 l/s He/H <sub>2</sub>
<b>Pumping speed*, AVS 4.1 (1963)</b>	1,200 l/s air
<b>Maximum throughput</b>	1.5 T-l/s (2.0 mbar-l/s) in operating range, 2.5 T-l/s (3.2 mbar-l/s) @ 0.01 Torr
<b>Operating range</b>	$2 \times 10^{-3}$ to $<5 \times 10^{-9}$ Torr ( $2.7 \times 10^{-3}$ to $<6.5 \times 10^{-9}$ mbar)
<b>Maximum forepressure</b>	No load: 0.65 Torr (0.86 mbar) Full load: 0.55 Torr (0.73 mbar)
<b>Recommended backing pump</b>	$\geq 10$ cfm (17 m <sup>3</sup> /hr)
<b>Backstreaming rate**, standard cold cap</b>	$<5 \times 10^{-4}$ mg/cm <sup>2</sup> /min
<b>Warmup time</b>	10 minutes
<b>Cooldown time</b>	10 minutes (with quick cool coil)
<b>Fluid charge</b>	300 cc
<b>Electrical requirements</b>	1 ph, 50/60 Hz, 120/208/240 VAC
<b>Pump power</b>	1450 watts
<b>Cooling water requirements</b>	0.15 gpm (30 l/hr) at 60-80 °F (15-26 °C)
<b>Water connections</b>	1/8 in. FPT Tee

\* For an explanation of pumping speed measurements, please see page 160.

\*\* Refer to page 158 for a description of test methods.



# DIFFUSION PUMPS

## VHS-4 Pumping Speed - Air/N<sub>2</sub>

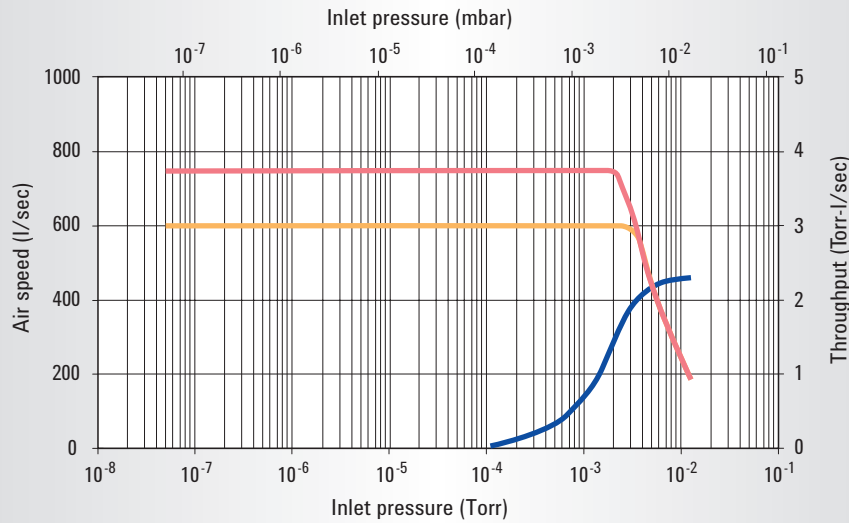

— Pumping speed/Standard cold cap    — Pumping speed/Extended cold cap    — Throughput

## Ordering Information

Description	Voltage	Weight kg (lbs)	Part Number	
			Flange Type ASA	ISO
<b>VHS-4 Pump</b>				
VHS-4 with standard cold cap	120 V	25.0 (55.0)	86460301	L6256301
VHS-4 with extended cold cap	120 V	25.0 (55.0)	86460311	L6256311
VHS-4 with standard cold cap	208 V	25.0 (55.0)	86460306	L6256306
VHS-4 with extended cold cap	208 V	25.0 (55.0)	86460316	L6256316
VHS-4 with standard cold cap	240 V	25.0 (55.0)	86460302	L6256302
VHS-4 with extended cold cap	240 V	25.0 (55.0)	86460312	L6256312

Accessories	Page	Weight kg (lbs)	Part Number
Water-cooled baffle with ASA flanges	157	4.5 (10.0)	F8286304
Water-cooled baffle with ISO flanges	157	4.5 (10.0)	F8286305
Centering ring for ISO inlet flange, 160K		0.5 (1.0)	IC160SV
Centering ring for ISO foreline flange, KF40		0.2 (0.5)	KC40SV
Santovac 5 diffusion pump fluid, 500 cc	156	1.1 (2.5)	695405005
Installation and Operation Manual			699901021

### Replacement Parts (one heater required per pump)

1450 W, 120 V heater		0.5 (1.0)	647304205
1450 W, 208 V heater		0.5 (1.0)	647304210
1450 W, 240 V heater		0.5 (1.0)	647304250
Heater clamp (one required per pump)		1.0 (2.0)	88164301
VHS-4 heater wire, 10 AWG, 24 inches (3 per pump required)		0.5 (0.2)	X3901-68001
Replacement o-ring kit (kit contains: 3 inlet flange o-rings (butyl 2-258), 10 fill and drain o-rings (Viton 2-113), sight glass o-ring and gasket)		0.5 (1.0)	K0377183
Thermal switch (set at 300 °F – 147 °C)		0.5 (1.0)	642906025
Extended cold cap	157	0.5 (1.0)	F6898301
Sight glass repair kit			L8908301

- NOTE**
- Inlet flange 4 in. ASA, foreline flange KF40
  - Inlet flange ISO 160K, foreline flange ISO KF40
  - Pumps with ISO flanges do not include required centering rings

## PUMP MODELS

### ► Agilent VHS-6

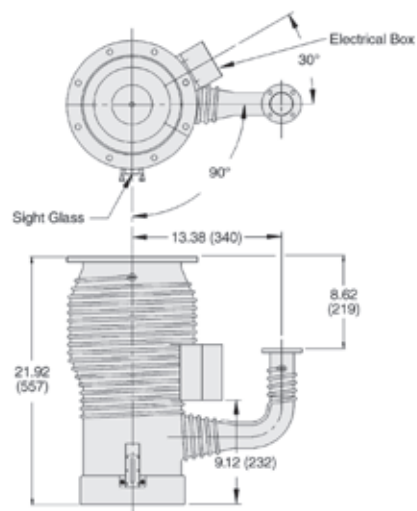

Dimensions: inches (millimeters)

### Technical Specifications

<b>Pumping speed, operating range</b>	1,550 l/s air, 1,930 l/s He/H <sub>2</sub>
<b>Pumping speed*, AVS 4.1 (1963)</b>	2,400 l/s air
<b>Maximum throughput</b>	2.4 T-l/s (3.2 mbar-l/s) in operating range, 3.5 T-l/s (4.5 mbar-l/s) @ 0.01 Torr
<b>Operating range</b>	$1.5 \times 10^{-3}$ to $<5 \times 10^{-9}$ Torr ( $2 \times 10^{-3}$ to $<6.5 \times 10^{-9}$ mbar)
<b>Maximum forepressure</b>	No load: 0.65 Torr (0.85 mbar) Full load: 0.55 Torr (0.72 mbar)
<b>Recommended backing pump</b>	$\geq 17$ cfm (29 m <sup>3</sup> /hr)
<b>Backstreaming rate**, standard cold cap</b>	$<5 \times 10^{-4}$ mg/cm <sup>2</sup> /min
<b>Warmup time</b>	10 minutes
<b>Cooldown time</b>	10 minutes (with quick cool coil)
<b>Fluid charge</b>	500 cc – exact fluid charge available
<b>Electrical requirements</b>	1 ph, 50/60 Hz, 120/208/240 VAC
<b>Pump power</b>	2200 watts
<b>Cooling water requirements</b>	0.25 gpm (50 l/hr) at 60-80 °F (15-26 °C)
<b>Water connections</b>	1/8 in. FPT Tee

\* For an explanation of pumping speed measurements, please see page 160.

\*\* Refer to page 158 for a description of test methods.

# DIFFUSION PUMPS

## VHS-6 Pumping Speed - Air/N<sub>2</sub>

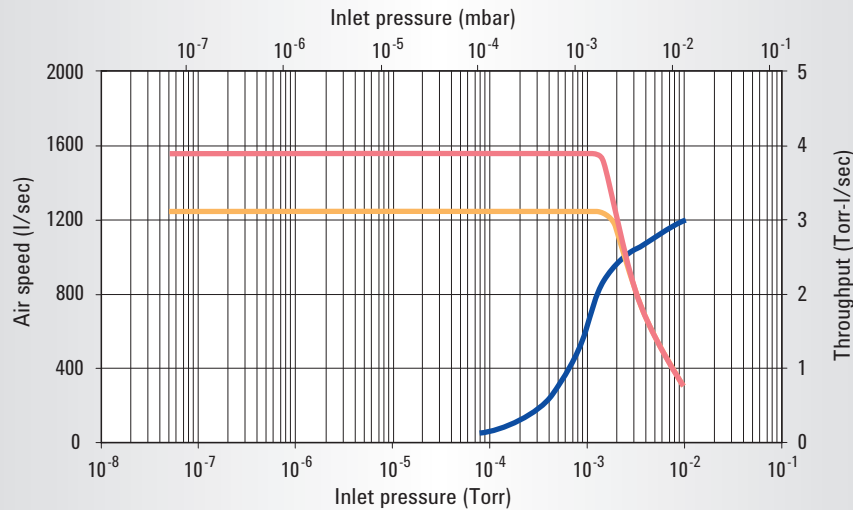

— Pumping speed/Standard cold cap    — Pumping speed/Extended cold cap    — Throughput

## Ordering Information

Description	Voltage	Weight kg (lbs)	Part Number	
			Flange Type ASA	ISO
<b>VHS-6 Pump</b>				
VHS-6 with standard cold cap	120 V	34.0 (75.0)	85826301	L6193301
VHS-6 with extended cold cap	120 V	34.0 (75.0)	85826311	L6193311
VHS-6 with standard cold cap	208 V	34.0 (75.0)	85826306	L6193306
VHS-6 with extended cold cap	208 V	34.0 (75.0)	85826316	L6193316
VHS-6 with standard cold cap	240 V	34.0 (75.0)	85826302	L6193302
VHS-6 with extended cold cap	240 V	34.0 (75.0)	85826312	L6193312
<b>Accessories</b>				
	<b>Page</b>	<b>Weight kg (lbs)</b>	<b>Part Number</b>	
Water-cooled baffle with ASA flanges	157	7.0 (15.0)	F8277306	
Water-cooled baffle with ISO flanges	157	7.0 (15.0)	F8277307	
Santovac 5 diffusion pump fluid, 500 cc (exact pump charge)	156	1.1 (2.5)	695405005	
Centering ring for ISO inlet flange, 200K		0.5 (1.0)	IC200SV	
Centering ring for ISO foreline flange, KF50		0.2 (0.5)	KC50SV	
Installation and Operation Manual			699901022	
<b>Replacement Parts (one heater required per pump)</b>				
2200 W, 120 V heater		0.5 (1.0)	647306125	
2200 W, 208 V heater		0.5 (1.0)	647306175	
2200 W, 240 V heater		0.5 (1.0)	647306225	
Heater clamping assembly (includes clamping plate, cover plate, insulator)			86643301	
Heater cover plate (one required per pump)		1.0 (2.0)	86088001	
Heater insulator (one required per pump)		0.2 (0.5)	86087001	
Heater clamping plate (one required per pump)		0.5 (1.0)	86086301	
VHS-6/250 heater wire, 10 AWG, 36 inches (3 per pump required)		0.5 (2.0)	X3901-68002	
Replacement o-ring kit (kit contains: 3 inlet flange o-rings (butyl 2-267), 3 foreline flange o-rings (butyl 2-332), sight glass o-ring and gasket, 10 fill and drain o-rings (Viton 2-113))		0.5 (1.0)	K0377184	
Thermal switch (set at 300 °F – 147 °C)		0.5 (1.0)	642906025	
Extended cold cap	157	0.5 (1.0)	F6455001	

**NOTE**

- Inlet flange 6 in. ASA, foreline flange 1.5 in. ASA
- Inlet flange ISO 200K, foreline flange ISO KF50
- Pumps with ISO flanges do not include required centering rings

## PUMP MODELS

### ► Agilent VHS-250

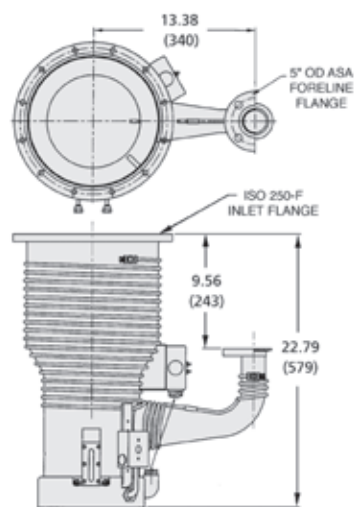

Dimensions: inches (millimeters)

### Technical Specifications

<b>Pumping speed, operating range</b>	2,125 l/s air, 2,660 l/s He/H <sub>2</sub>
<b>Pumping speed*, AVS 4.1 (1963)</b>	3,700 l/s air
<b>Maximum throughput</b>	2.6 T-l/s (3.5 mbar-l/s) in operating range, 3.5 T-l/s (4.5 mbar l/s) @ 0.01 Torr
<b>Operating range</b>	$1.2 \times 10^{-3}$ to $<5 \times 10^{-9}$ Torr ( $1.6 \times 10^{-3}$ to $<6.5 \times 10^{-9}$ mbar)
<b>Maximum forepressure</b>	No load: 0.65 Torr (0.85 mbar) Full load: 0.55 Torr (0.72 mbar)
<b>Recommended backing pump</b>	$\geq 17$ cfm (29 m <sup>3</sup> /hr)
<b>Backstreaming rate**, standard cold cap</b>	$< 5.0 \times 10^{-4}$ mg/cm <sup>2</sup> /min
<b>Warmup time</b>	10 minutes
<b>Cooldown time</b>	10 minutes (with quick cool coil)
<b>Fluid charge</b>	500 cc – exact fluid charge available
<b>Electrical requirements</b>	1 ph, 50/60 Hz, 120/208/240 VAC
<b>Pump power</b>	2200 watts
<b>Cooling water requirements</b>	0.25 gpm (50 l/hr)
<b>Water connections</b>	1/8 in. FPT Tee

\* For an explanation of pumping speed measurements, please see page 160.

\*\* Refer to page 158 for a description of test methods.



# DIFFUSION PUMPS

## VHS-250 Pumping Speed - Air/N<sub>2</sub>

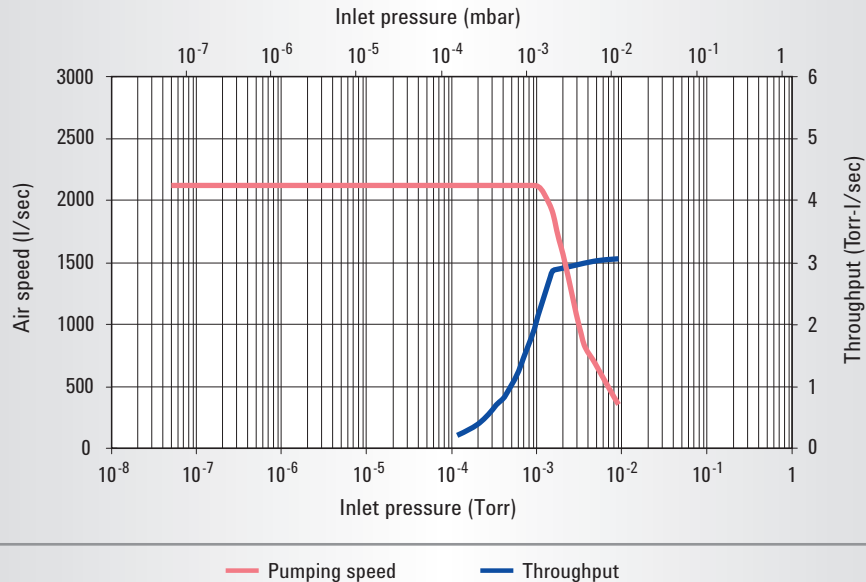

## Ordering Information

Description	Voltage	Weight kg (lbs)	Part Number
VHS-250 pump			
VHS-250 with standard cold cap	120 V	34.0 (75.0)	K0543301
VHS-250 with standard cold cap	208 V	34.0 (75.0)	K0543306
VHS-250 with standard cold cap	240 V	34.0 (75.0)	K0543302

## Accessories

Santovac 5 diffusion pump fluid, 500 cc (exact pump charge)		1.1 (2.5)	695405005
Installation and Operation Manual			699901020

## Replacement Parts (one heater required per pump)

2200 W, 120 V heater		0.5 (1.0)	647306125
2200 W, 208 V heater		0.5 (1.0)	647306175
2200 W, 240 V heater		0.5 (1.0)	647306225
Heater cover plate (one required per pump)		1.0 (2.0)	86088001
Heater insulator (one required per pump)		0.2 (0.5)	86087001
Heater clamping plate (one required per pump)		0.5 (1.0)	86086301
VHS-6/250 heater wire, 10 AWG, 36 inches (3 per pump required)		0.5 (2.0)	X3901-68002
Replacement o-ring kit (kit contains: 3 inlet flange o-rings (butyl 2-379), 3 foreline flange o-rings (butyl 2-332), sight glass o-ring and gasket, 10 fill and drain o-rings (Viton 2-113))		0.5 (1.0)	K0377178
Thermal switch (set at 300 °F – 147 °C)		0.5 (1.0)	642906025

**NOTE**

- Inlet flange: ISO 250F (bolted, o-ring seal)
- Foreline flange: ASA with 5 in. OD

## PUMP MODELS

### ► Agilent VHS-10

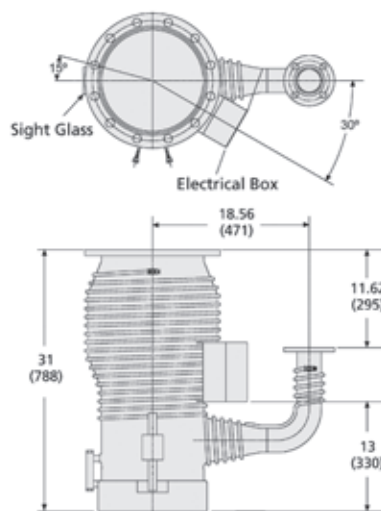

Dimensions: inches (millimeters)

### Technical Specifications

<b>Pumping speed, operating range</b>	3,650 l/s air, 4,560 l/s He/H <sub>2</sub>
<b>Pumping speed*, AVS 4.1 (1963)</b>	5,300 l/s air
<b>Maximum throughput</b>	6.3 T-l/s (8.4 mbar l/s) in operating range, 7.5 T-l/s (10.0 mbar l/s) @ 0.01 Torr
<b>Operating range</b>	$1.7 \times 10^{-3}$ to $<5 \times 10^{-9}$ Torr at 4400 W ( $2.3 \times 10^{-3}$ to $<6.5 \times 10^{-9}$ mbar)
<b>Maximum forepressure</b>	No load: 0.65 Torr (0.85 mbar) Full load: 0.55 Torr (0.72 mbar)
<b>Recommended backing pump</b>	$\geq 30$ cfm (51 m <sup>3</sup> /hr)
<b>Backstreaming rate**, standard cold cap</b>	$<5.0 \times 10^{-4}$ mg/cm <sup>2</sup> /min
<b>Warmup time</b>	15 minutes
<b>Cooldown time</b>	25 minutes
<b>Fluid charge</b>	1,000 cc
<b>Electrical requirements</b>	3 ph, 50/60 Hz, 208/240/380/480 VAC
<b>Pump power</b>	4400 watts
<b>Cooling water requirements</b>	0.40 gpm (80 l/hr)
<b>Water connections</b>	1/8 in. FPT Tee

\* For an explanation of pumping speed measurements, please see page 160.

\*\* Refer to page 158 for a description of test methods.

# DIFFUSION PUMPS

## VHS-10 Pumping Speed - Air/N<sub>2</sub>

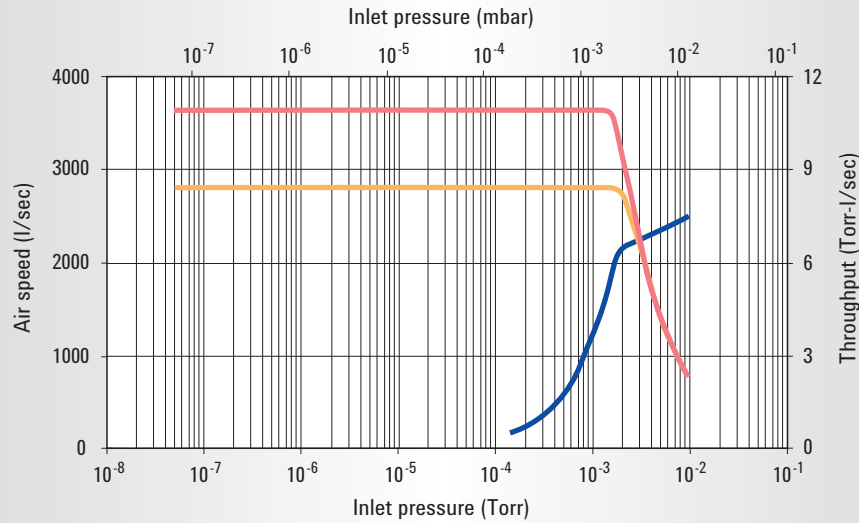

— Pumping speed/Standard cold cap    — Pumping speed/Extended cold cap    — Throughput

## Ordering Information

Description	Wt. kg (lbs)	Part Number	
		ASA	ISO
VHS-10 with standard cold cap, 208 V	68 (150)	F0426307	L5920307
VHS-10 with extended cold cap, 208 V	68 (150)	F0426317	L5920317
VHS-10 with standard cold cap, 240 V	68 (150)	F0426308	L5920308
VHS-10 with extended cold cap, 240 V	68 (150)	F0426318	L5920318
VHS-10 with standard cold cap, 380 V	68 (150)	F0426326	L5920326
VHS-10 with extended cold cap, 380 V	68 (150)	F0426336	L5920336
VHS-10 with standard cold cap, 480 V	68 (150)	F0426309	L5920309
VHS-10 with extended cold cap, 480 V	68 (150)	F0426319	L5920319

Accessories	Wt. kg (lbs)	Part Number
Water-cooled baffle with ASA flanges	9.0 (20.0)	F8600310
Water-cooled baffle with ISO flanges	9.0 (20.0)	F8600311

**NOTE** • Inlet flange 10 in. ASA, foreline flange 2 in. ASA  
 • Inlet flange ISO 320K, foreline ISO 63K  
 • See page 156 Santovac 5 diffusion pump fluid  
 • Baffles and extended cold caps can be found on page 157

Description	Wt. kg (lbs)	Part Number
<b>Accessories (Cont'd)</b>		
Centering ring for ISO foreline flange, 63K	0.5 (1.0)	IC063SV
Installation and Operation Manual		699901023

<b>Replacement Parts (two heaters required per pump)</b>		
2200 W, 208 V heater	0.5 (1.0)	647310140
2200 W, 240 V heater	0.5 (1.0)	647310150
2200 W, 380 V heater	0.5 (1.0)	647310160
2200 W, 480 V heater	0.5 (1.0)	647310170
2550 W, 208 V heater	0.5 (1.0)	647310145
2550 W, 240 V heater	0.5 (1.0)	647310155
2550 W, 380 V heater	0.5 (1.0)	647310165
2550 W, 480 V heater	0.5 (1.0)	647310175
Heater crush plate (covers both heaters; one required for pump; replace when either heater is replaced)	1.0 (2.0)	K7667001
Heater clamping plate (one required per pump)	0.5 (1.0)	R2667301
VHS-10/400 heater wire, 10 AWG, 42 inches (3 per pump required)	1.0 (0.4)	X3901-68003
Replacement o-ring kit (kit contains: 1 inlet flange o-ring (butyl F0430001), 1 foreline flange o-ring (butyl 2-338), sight glass o-ring and gasket, 10 fill and drain o-rings (Viton 2-113))	1.0 (0.5)	K0377185
Thermal switch (set at 300 °F – 147 °C)	0.5 (1.0)	642906025
Extended cold cap	2.0 (0.9)	L8917301

## PUMP MODELS

### ▶ Agilent VHS-400

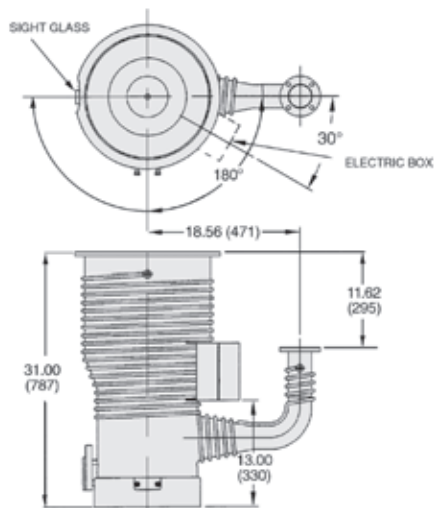

Dimensions: inches (millimeters)

### Technical Specifications

<b>Pumping speed, operating range</b>	4,500 l/s air, 5,625 l/s He/H <sub>2</sub>
<b>Pumping speed*, AVS 4.1 (1963)</b>	8,000 l/s air
<b>Maximum throughput</b>	6.3 T-l/s (8.4 mbar l/s) in operating range, 7.5 T-l/s (10.0 mbar l/s) @ 0.01 Torr
<b>Operating range</b>	$1.4 \times 10^{-3}$ to $<5 \times 10^{-9}$ Torr ( $1.9 \times 10^{-3}$ to $<6.5 \times 10^{-9}$ mbar)
<b>Maximum forepressure</b>	No load: 0.65 Torr (0.85 mbar) Full load: 0.55 Torr (0.72 mbar)
<b>Recommended backing pump</b>	$\geq 30$ cfm (51 m <sup>3</sup> /hr)
<b>Backstreaming rate**, standard cold cap</b>	$<1.0 \times 10^{-3}$ mg/cm <sup>2</sup> /min
<b>Warmup time</b>	15 minutes
<b>Cooldown time</b>	25 minutes
<b>Fluid charge</b>	1,000 cc
<b>Electrical requirements</b>	3 ph, 50/60 Hz, 208/380/480 VAC
<b>Pump power</b>	4400 watts
<b>Cooling water requirements</b>	0.40 gpm (80 l/hr)
<b>Water connections</b>	1/8 in. FPT Tee

\* For an explanation of pumping speed measurements, please see page 160.

\*\* Refer to page 158 for a description of test methods.



# DIFFUSION PUMPS

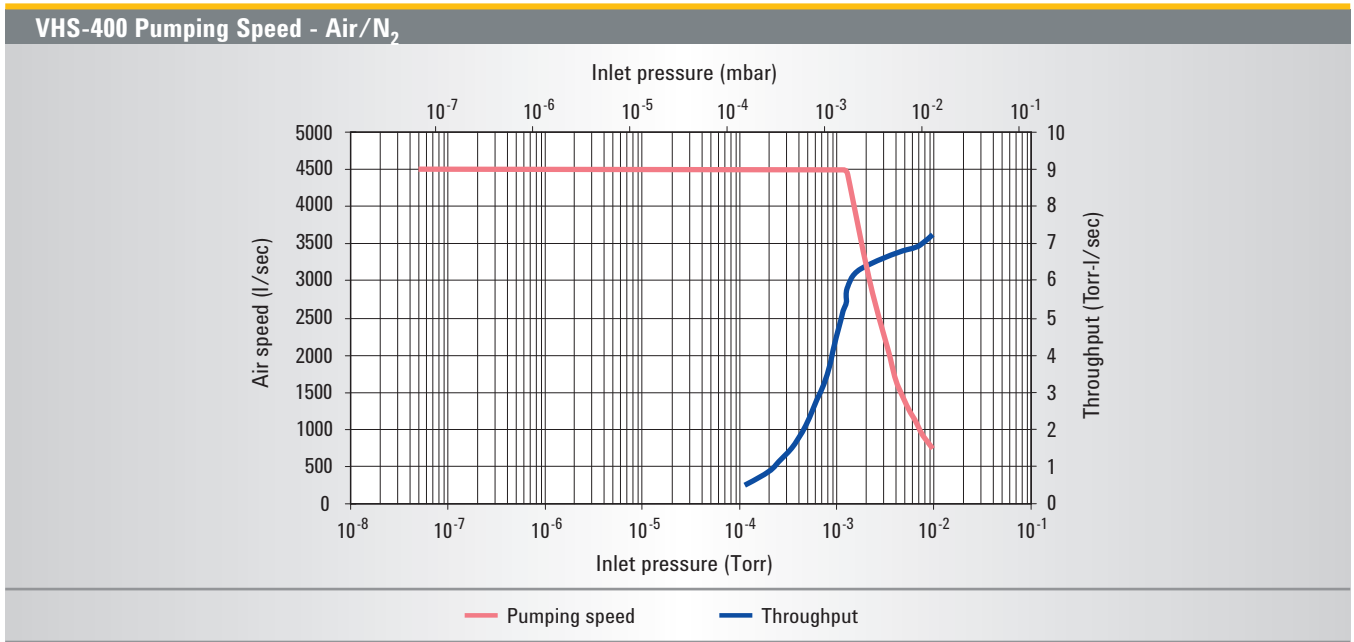

## Ordering Information

Description	Voltage	Weight kg (lbs)	Part Number	
			Flange Type ASA	ISO
<b>VHS-400 Pump</b>				
VHS-400 with standard cold cap	208 V	75.0 (180.0)	K4816307	L9767307
VHS-400 with standard cold cap	380 V	75.0 (180.0)	K4816326	L9767326
VHS-400 with standard cold cap	480 V	75.0 (180.0)	K4816309	L9767309
VHS-400 with standard cold cap	240 V	75.0 (180.0)	K4816308	L9767308

Accessories	Page	Weight kg (lbs)	Part Number
Centering ring for ISO Inlet flange, 400K		0.5 (1.0)	IC400SV
Centering ring for ISO foreline flange, 63K		0.5 (1.0)	IC063SV
Installation and Operation Manual			699901023

### Replacement Parts (two heaters required per pump)

2200 W, 208 V heater		1.0 (0.5)	647310140
2200 W, 240 V heater		1.0 (0.5)	647310150
2200 W, 380 V heater		1.0 (0.5)	647310160
2200 W, 480 V heater		1.0 (0.5)	647310170
2550 W, 208 V heater		1.0 (0.5)	647310145
2550 W, 240 V heater		1.0 (0.5)	647310155
2550 W, 380 V heater		1.0 (0.5)	647310165
2550 W, 480 V heater		1.0 (0.5)	647310175
Heater crush plate (one required per pump; replace when either heater is replaced)		2.0 (1.0)	K7667001
Heater clamping plate (one required per pump)		1.0 (0.5)	R2667301
VHS-10/400 heater wire, 10 AWG, 42 inches (3 per pump required)		1.0 (0.4)	X3901-68003
Replacement o-ring kit (kit contains: 1 inlet flange o-ring (butyl 2-385), foreline flange o-ring (butyl 2-338), sight glass o-ring and gasket, 10 fill and drain o-rings (Viton 2-113))		1.0 (0.5)	K0377189
Thermal switch (set at 300 °F – 147 °C)		1.0 (0.5)	642906025

- NOTE**
- Inlet flange ISO 400K, foreline flange ISO 63-K.
  - Inlet flange non-standard ASA, foreline flange 2 in. ASA.
  - Pumps with ASA flanges include O-Rings for inlet and foreline flanges
  - Pumps with ISO flanges do not include centering rings required for inlet and foreline flanges.

# PUMP MODELS

## ▶ Agilent HS-16

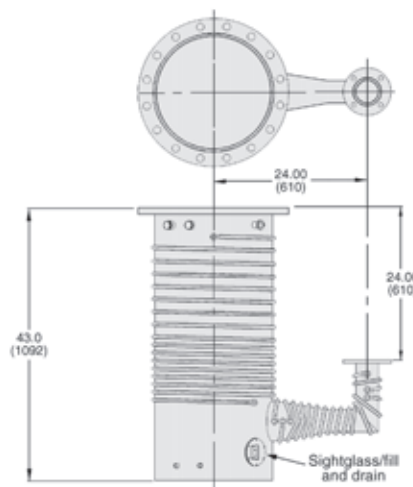

Dimensions: inches (millimeters)

### HS-16 Pumping Speed - Air/N<sub>2</sub>

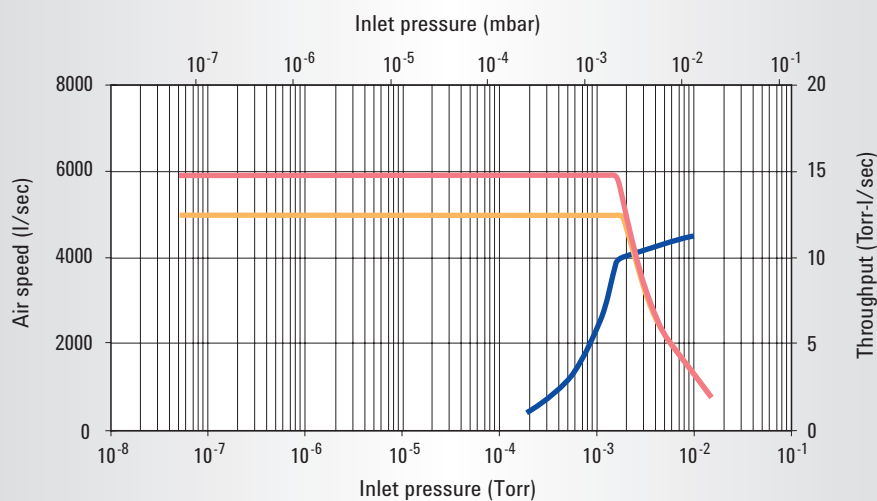

— Pumping speed/Cold cap      — Pumping speed/Halo baffle      — Throughput

### Technical Specifications

<b>Pumping speed, operating range</b>	6,000 l/s air, 7,500 l/s He and H <sub>2</sub>
<b>Pumping speed*, AVS 4.1 (1963)</b>	10,000 l/s air
<b>Maximum throughput</b>	8,100 W – 9.5 T-l/s (12.7 mbar l/s) in operating range 13.5 T-l/s (18.0 mbar-l/s) @ 0.01 Torr 9,600 W –12.0 T-l/s (16 mbar l/s) in operating range 11.5 T-l/s (15.3 mbar-l/s) @ 0.01 Torr
<b>Operating range</b>	2 x 10 <sup>-3</sup> to <5 x 10 <sup>-8</sup> Torr at 9,600 W (1.3 x 10 <sup>-3</sup> to <6.5 x 10 <sup>-8</sup> mbar)
<b>Maximum forepressure</b>	No load – 0.65 Torr (0.85 mbar), Full Load – 0.55 Torr (0.72 mbar)
<b>Pump power</b>	8100/9600 watts
<b>Recommended backing pump</b>	≥ 80 cfm (136 m <sup>3</sup> /hr)
<b>Backstreaming rate**, standard cold cap</b>	<1.5 x 10 <sup>-3</sup> mg/cm <sup>2</sup> /min
<b>Warmup time</b>	30 minutes
<b>Cooldown time</b>	48 minutes (30 minutes with optional quick cool coil)
<b>Fluid charge</b>	3 quarts (2.8 liters)
<b>Electrical requirements</b>	3 ph, 50/60 Hz, 240/415/480 VAC
<b>Cooling water requirements</b>	1.5 gpm (300 l/hr) at 60-80 °F (15-26 °C)
<b>Water connections</b>	¼ in. FPT Tee

\* For an explanation of pumping speed measurements, please see page 160.

\*\* Refer to page 158 for a description of test methods.

# DIFFUSION PUMPS

## Ordering Information

Description	Voltage	Weight kg (lbs)	Part Number	
			Flange Type ASA	ISO
<b>HS-16 Pump</b>				
HS-16 with standard cold cap	240 V	218.0 (480.0)	79292308	L5921308
HS-16 with halo baffle	240 V	218.0 (480.0)	79292318	L5921318
HS-16 with standard cold cap	415 V	218.0 (480.0)	79292326	L5921326
HS-16 with halo baffle	415 V	218.0 (480.0)	79292336	L5921336
HS-16 with standard cold cap	480 V	218.0 (480.0)	79292309	L5921309
HS-16 with halo baffle	480 V	218.0 (480.0)	79292319	L5921319

**NOTE** • The HS-16 can be ordered with 9600 W heaters by increasing the middle number of the 3-digit suffix by two; eg 79292328

Accessories	Page	Weight kg (lbs)	Part Number
Water-cooled halo baffle	157	9.0 (20.0)	K0143316
Centering ring for ISO foreline flange, 100K		0.5 (1.0)	IC100SV
Quick cool coil – must be installed in the factory			Factory Special
Installation and Operation Manual			699901140

### Replacement Parts (three heaters required per pump)

2700 W, 240 V/415 V with leads		0.5 (1.0)	647316020
2700 W, 480 V with leads		0.5 (1.0)	647316030
2700 W, 240 V/415 V no leads – used on pumps built before May '90		0.5 (1.0)	647316035
2700 W, 480 V no leads – used on pumps built before May '90		0.5 (1.0)	647316045
3200 W, 240 V/415 V with leads		0.5 (1.0)	647316023
3200 W, 480 V with leads		0.5 (1.0)	647316033
Heater crush plate (replace one with each new heater)		0.5 (1.0)	K4919001
Heater insulator (three required per pump)		0.5 (1.0)	79309001
Heater clamping plate (three required per pump)		4.0 (8.0)	K4917001
HS-16/20/Dalton heater wire, 10 AWG, 120 inches (2 per heater required)		1.0 (0.4)	X3900-68000
Replacement o-ring kit for ASA pumps (kit contains: 1 inlet flange o-ring (buna 48214001), 1 foreline flange o-ring (buna 2-348), sight glass o-ring and gasket, 8 fill and drain o-rings (Viton 2-213))		0.5 (1.0)	K0377164
Sight glass service kit (pumps built before Oct. '95)		1.5 (3.0)	F6097301
Upper (water) thermal switch (set at 185 °F/85 °C)		0.5 (1.0)	K9050001
Lower (boiler) thermal switch (set at 390 °F/199 °C)		0.5 (1.0)	K9050002
Cold cap gasket/grommet (kit of 4)		0.5 (1.0)	L8839301
Cold cap nut and follower (2 each)		0.5 (1.0)	L8840301

**NOTE**

- Inlet flange 16 in. ASA, foreline flange 3 in. ASA
- Inlet flange ISO 500K, foreline flange ISO 100K
- Not recommended for use with Santovac 5
- Pumps with ASA flanges include o-rings for inlet and foreline flanges
- Pumps with ISO flanges do not include centering rings required for foreline and inlet flanges

# PUMP MODELS

## ▶ Agilent HS-20

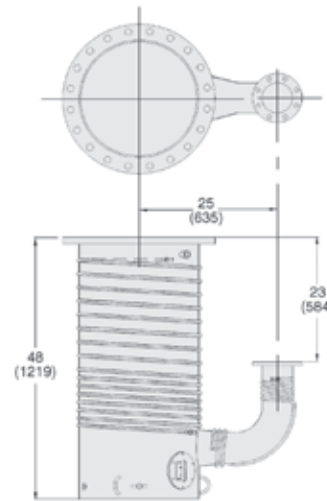

Dimensions: inches (millimeters)

### HS-20 Pumping Speed - Air/N<sub>2</sub>

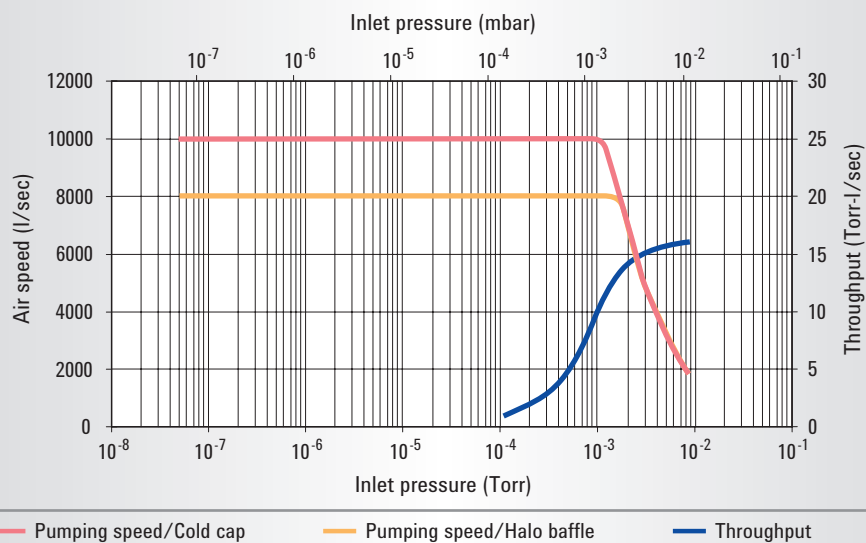

### Technical Specifications

<b>Pumping speed, operating range</b>	10,000 l/s air, 12,500 l/s He and H <sub>2</sub>
<b>Pumping speed*, AVS 4.1 (1963)</b>	17,500 l/s air
<b>Maximum throughput</b>	12.5 T-l/s (16.7 mbar l/s) in operating range, 18 T-l/s (23 mbar-l/s) @ 0.01 Torr
<b>Operating range</b>	1.3 x 10 <sup>-3</sup> to 5 x 10 <sup>-8</sup> Torr (1.7 x 10 <sup>-3</sup> to 6.5 x 10 <sup>-8</sup> mbar)
<b>Maximum forepressure</b>	No load: 0.65 Torr (0.85 mbar) Full load: 0.55 Torr (0.72 mbar)
<b>Recommended backing pump</b>	≥100 cfm (170 m <sup>3</sup> /hr)
<b>Backstreaming rate**, standard cold cap</b>	<1.5 x 10 <sup>-3</sup> mg/cm <sup>2</sup> /min
<b>Warmup time</b>	45 minutes
<b>Cooldown time</b>	85 minutes
<b>Fluid charge</b>	5 quarts (4.7 liters)
<b>Electrical requirements</b>	3 ph, 50/60 Hz, 240/415/480 VAC
<b>Pump power</b>	12,000 watts
<b>Cooling water requirements</b>	1.5 gpm (300 l/hr) at 60-80 °F (15-26 °C)
<b>Water connections</b>	¼ in. FPT Tee

\* For an explanation of pumping speed measurements, please see page 160.

\*\* Refer to page 158 for a description of test methods.

# DIFFUSION PUMPS

## Ordering Information

Description	Voltage	Weight kg (lbs)	Part Number	
			Flange Type ASA	ISO
<b>HS-20 Pump</b>				
HS-20 with standard cold cap	240 V	264.0 (580.0)	84341308	L5922308
HS-20 with halo baffle	240 V	264.0 (580.0)	84341318	L5922318
HS-20 with standard cold cap	415 V	264.0 (580.0)	84341326	L5922326
HS-20 with halo baffle	415 V	264.0 (580.0)	84341336	L5922336
HS-20 with standard cold cap	480 V	264.0 (580.0)	84341309	L5922309
HS-20 with halo baffle	480 V	264.0 (580.0)	84341319	L5922319

Accessories	Page	Weight kg (lbs)	Part Number
Water-cooled halo baffle	157	11.0 (25.0)	K1855320
Centering ring for ISO foreline flange, 160K		0.5 (1.0)	IC160SV
Quick cool coil – must be installed in the factory			Factory Special
Installation and Operation Manual			699901140

### Replacement Parts (six heaters required per pump)

Heater, 2000 W, 240 V/415 V with leads	0.5 (1.0)	647320020
Heater, 2000 W, 480 V with leads	0.5 (1.0)	647320030
Heater, 2000 W, 240 V/415 V no leads – used on pumps built before May '90	0.5 (1.0)	647320060
Heater, 2000 W, 480 V no leads – used on pumps built before May '90	0.5 (1.0)	647320070
Heater crush plate (replace one with each new heater)	0.5 (1.0)	K7108001
Heater clamping plate (six required per pump)	4.0 (8.0)	K7107001
Heater insulator (one required per pump)	0.5 (1.0)	L6514001
HS-16/20/Dalton heater wire, 10 AWG, 120 inches (2 per heater required)	1.0 (0.4)	X3900-68000
Replacement o-ring kit for ASA pumps (kit contains 1 inlet flange o-ring (butyl 84349002), 1 foreline flange o-ring (buna 2-432), sight glass o-ring and gasket, 8 fill and drain o-rings (Viton 2-213))	0.5 (1.0)	K0377165
Sight glass service kit (pumps built before Oct. '95)	1.5 (3.0)	F6097301
Upper (water) thermal switch (set at 185 °F/85 °C)	0.5 (1.0)	K9050001
Lower (boiler) thermal switch (set at 390 °F/199 °C)	0.5 (1.0)	K9050002
Cold cap gasket/grommet (kit of 4)	0.5 (1.0)	L8839301
Cold cap nut and follower (2 each)	0.5 (1.0)	L8840301

- NOTE**
- Inlet flange 20 in. ASA, foreline flange 4 in. ASA
  - Inlet flange ISO 630K, foreline flange ISO 160K
  - Not recommended for use with Santovac 5
  - Pumps with ASA flanges include o-rings for inlet and foreline flanges
  - Pumps with ISO flanges do not include centering rings required for foreline and inlet flanges

## PUMP MODELS

### ► Agilent HS-32

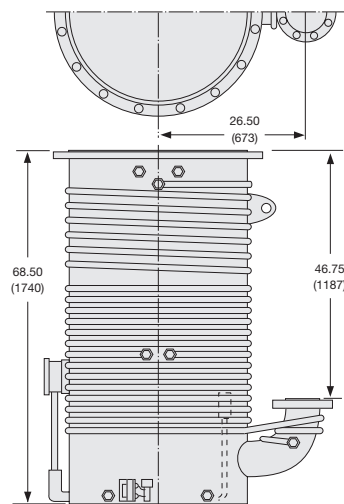

Dimensions: inches (millimeters)

### Technical Specifications

<b>Pumping speed, operating range</b>	17,300 l/s air, 21,625 l/s He and H <sub>2</sub>
<b>Pumping speed*, AVS 4.1 (1963)</b>	32,000 l/s air
<b>Maximum throughput</b>	30 T-l/s (40 mbar l/s) in operating range, 35 T-l/s (45 mbar-l/s) @ 0.01 Torr
<b>Operating range</b>	$1.7 \times 10^{-3}$ to $<5 \times 10^{-8}$ Torr ( $2.3 \times 10^{-3}$ to $<6.5 \times 10^{-8}$ mbar)
<b>Maximum forepressure</b>	No load: 0.50 Torr (0.65 mbar) Full load: 0.35 Torr (0.45 mbar)
<b>Recommended backing pump</b>	$\geq 300$ cfm (510 m <sup>3</sup> /hr)
<b>Backstreaming rate**, standard cold cap</b>	$<7 \times 10^{-4}$ mg/cm <sup>2</sup> /min
<b>Warmup time</b>	60 minutes
<b>Cooldown time</b>	180 minutes
<b>Fluid charge</b>	3 U.S. gallons (11.3 liters)
<b>Electrical requirements</b>	3 ph, 50/60 Hz, 240/415/480 VAC
<b>Pump power</b>	24,000 watts
<b>Cooling water requirements</b>	4 gpm (800 l/hr) at 60-80 °F (15-26 °C)
<b>Water connections</b>	$\frac{3}{8}$ in. FPT Tee

\* For an explanation of pumping speed measurements, please see page 160.

\*\* Refer to page 158 for a description of test methods.



# DIFFUSION PUMPS

## HS-32 Pumping Speed - Air/N<sub>2</sub>

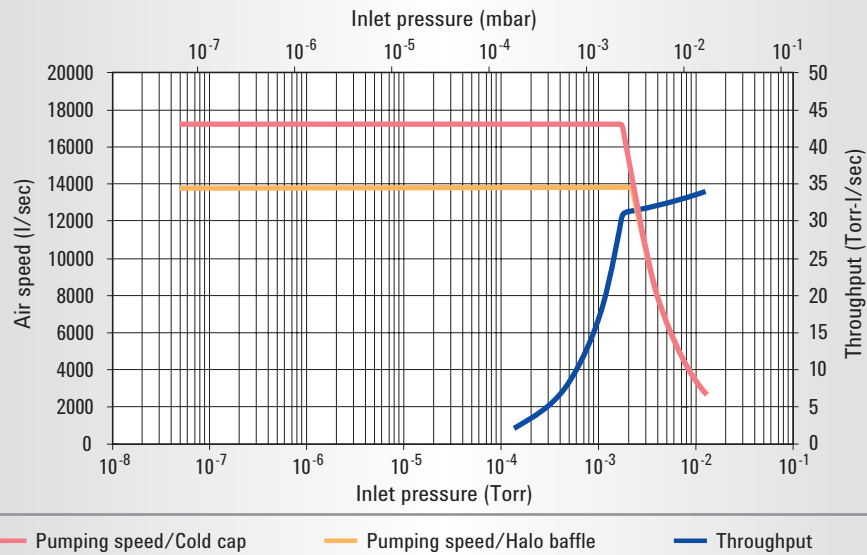

## Ordering Information

Description	Wt. kg (lbs)	Part Number	
		ASA	ISO
<b>HS-32 Pump</b>			
HS-32 with standard cold cap, 240 V	612 (1,350)	76134308	L5923308
HS-32 with halo baffle, 240 V	612 (1,350)	76134318	L5923318
HS-32 with standard cold cap, 415 V	612 (1,350)	76134326	L5923326
HS-32 with halo baffle, 415 V	612 (1,350)	76134336	L5923336
HS-32 with standard cold cap, 480 V	612 (1,350)	76134309	L5923309
HS-32 with halo baffle, 480 V	612 (1,350)	76134319	L5923319

Accessories	Wt. kg (lbs)	Part Number
Water-cooled halo baffle	16 (35)	K1856332
Quick cool coil – must be installed in the factory		Factory Special
Centering ring for ISO foreline flange, 200K	0.5 (1.0)	IC200SV
Installation and Operation Manual		699901140

- NOTE**
- Inlet flange 32 in. ASA, foreline flange 6 in. ASA
  - Inlet flange ISO 800F (bolted), foreline flange ISO 200K (clamped)
  - Not recommended for use with Santovac 5
  - ASA pump versions include o-rings for both inlet and foreline flanges
  - ISO pump versions include inlet flange o-ring, but does not include foreline flange centering ring

Description	Wt. kg (lbs)	Part Number
<b>Replacement Parts</b> (six heaters required per pump)		
Heater*, 4000 W, 240 V/415 V/480 V with leads	0.5 (1.0)	647332010
Heater*, 4000 W, 240 V/415 V/480 V no leads – used on pumps built before May '90	0.5 (1.0)	647332075
<i>*One heater consists of 2-120V heaters, right and left</i>		
Heater crush plate (replace one with each new heater)	0.5 (1.0)	K7246001
Heater insulator (one required per pump)	0.5 (1.0)	75792001
Heater clamping plate (six required per pump)	4 (8)	K7247001
HS-32/35 heater wire, 10 AWG, 196 inches (2 per heater required)	1.0 (0.4)	X3900-68003
Replacement o-ring kit for ASA pumps (kit contains: 1 inlet flange o-ring (buna 45390001), 1 foreline flange o-ring (butyl 2-443), sight glass o-ring and gasket, 8 fill and drain o-rings (Viton 2-213))	0.5 (1.0)	K0377167
Sight glass service kit (pumps built before Oct. '95)	1.5 (3.0)	F6097301
Sight glass service kit (pumps built after Oct. '95)	1.5 (3.0)	L9223001
ISO inlet flange o-ring	0.5 (1.0)	78536002
Upper (water) thermal switch (set at 220 °F/104 °C)	0.5 (1.0)	K9050005
Lower (boiler) thermal switch (set at 550 °F/288 °C)	0.5 (1.0)	K9050004
Cold cap gasket/grommet (kit of 4)	0.5 (1.0)	L8839301
Cold cap nut and follower (2 each)	0.5 (1.0)	L8840301

Please note that this item is controlled for export by the Nuclear Suppliers Group. Accordingly, you may be required to obtain export licenses, including from US government authorities prior to exporting this diffusion pump from the United States. Please contact Agilent Vacuum Products, and the U.S. Export Administration regulations ECCN 2B231 for further guidance.

# PUMP MODELS

## ▶ Agilent NHS-35

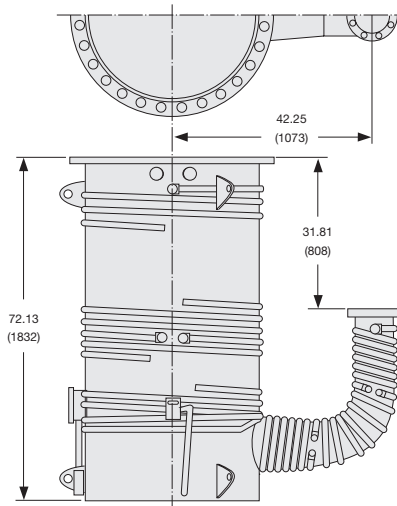

Dimensions: inches (millimeters)

### NHS-35 Pumping Speed - Air/N<sub>2</sub>

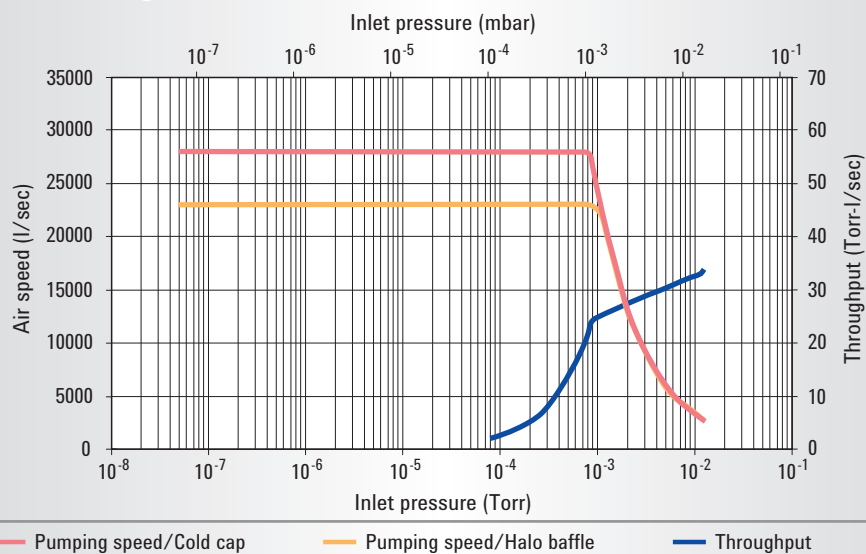

### Technical Specifications

<b>Pumping speed, operating range</b>	28,000 l/s air, 35,000 l/s He and H <sub>2</sub>
<b>Pumping speed*, AVS 4.1 (1963)</b>	50,000 l/s air
<b>Maximum throughput</b>	25 T-l/s (33 mbar l/s) in operating range, 35 T-l/s (45 mbar-l/s) @ 0.01 Torr
<b>Operating range</b>	9 x 10 <sup>-4</sup> to < 5 x 10 <sup>-8</sup> Torr (1.2 x 10 <sup>-3</sup> < 6.5 x 10 <sup>-8</sup> mbar)
<b>Maximum forepressure</b>	No load – 0.55 Torr (0.71 mbar), Full Load – 0.40 Torr (0.52 mbar)
<b>Recommended backing pump</b>	≥300 cfm (510 m <sup>3</sup> /hr)
<b>Backstreaming rate**, standard cold cap</b>	<5 x 10 <sup>-4</sup> mg/cm <sup>2</sup> /min
<b>Warmup time</b>	60 minutes
<b>Cooldown time</b>	180 minutes
<b>Fluid charge</b>	3 U.S. gallons (11.3 liters)
<b>Electrical requirements</b>	3 ph, 50/60 Hz, 240/415/480 VAC
<b>Pump power</b>	24,000 watts
<b>Cooling water requirements</b>	4 gpm (800 l/hr) at 60-80 °F (15-26 °C)

\* For an explanation of pumping speed measurements, please see page 160.

\*\* Refer to page 158 for a description of test methods.

# DIFFUSION PUMPS

## Ordering Information

Description	Voltage	Weight kg (lbs)	Part Number	
			ASA	ISO
<b>NHS-35 Pump</b>				
NHS-35 with standard cold cap	240 V	680.0 (1,550.0)	F1730308	L5924308
NHS-35 with halo baffle	240 V	680.0 (1,550.0)	F1730318	L5924318
NHS-35 with standard cold cap	415 V	680.0 (1,550.0)	F1730326	L5924326
NHS-35 with halo baffle	415 V	680.0 (1,550.0)	F1730336	L5924336
NHS-35 with standard cold cap	480 V	680.0 (1,550.0)	F1730309	L5924309
NHS-35 with halo baffle	480 V	680.0 (1,550.0)	F1730319	L5924319

Accessories	Page	Weight kg (lbs)	Part Number
Water-cooled halo baffle	157	20.0 (45.0)	K1857335
Quick cool coil – must be installed in the factory, can not ship separately			Factory Special
Centering ring for ISO foreline flange, 200K		0.5 (1.0)	IC200SV
O-ring, ISO Inlet flange		0.5 (1.0)	78536002
Installation and Operation Manual			699901140

<b>Replacement Parts</b> (six heaters required per pump)			
Heater 4000 W, 240 V/480 V with leads		0.5 (1.0)	647335010
Heater 4000 W, 240 V/480 V no leads – used on pumps built before May '90		0.5 (1.0)	647235248
Heater, 4000 W, 200 V		0.5 (1.0)	647335020
Heater, 4000 W, 400 V		0.5 (1.0)	L6383010
Heater, 4000 W, 440 V		0.5 (1.0)	L6383011
Heat shield (reusable)		0.5 (1.0)	L6370001
Heater clamping plate (six required per pump)		4.0 (8.0)	F1749001
Heater insulator (one required per pump)		0.5 (1.0)	L9699001
HS-32/35 heater wire, 10 AWG, 196 inches (2 per heater required)		1.0 (0.4)	X3900-68003
Replacement o-ring kit for ASA pumps (kit contains: 1 inlet flange o-ring (buna 78536001), 1 foreline flange o-ring (butyl 2-267), sight glass o-ring and gasket, 8 fill and drain o-rings (Viton 2-213))		0.5 (1.0)	K0377169
Sightglass service kit (pumps built before Oct. '95)		1.5 (3.0)	F6097301
Upper (water) thermal switch (set at 200 °F/93 °C)		0.5 (1.0)	K9050005
Lower (boiler) thermal switch (set at 600 °F/316 °C)		0.5 (1.0)	K9050006
Cold cap gasket/grommet (kit of 4)		0.5 (1.0)	L8839301
Cold cap nut and follower (2 each)		0.5 (1.0)	L8840301

- NOTE**
- Inlet flange 35 in. ASA, foreline flange 6 in. ASA
  - Inlet flange ISO 1000F (bolted), foreline flange ISO 200K (clamped)
  - Not recommended for use with Santovac 5
  - ASA pump versions include o-rings for both inlet and foreline flanges
  - ISO pump versions include inlet flange o-ring, but does not include foreline flange centering ring

Please note that this item is controlled for export by the Nuclear Suppliers Group. Accordingly, you may be required to obtain export licenses, including from US government authorities prior to exporting this diffusion pump from the United States. Please contact Agilent Vacuum Products, and the U.S. Export Administration regulations ECCN 2B231 for further guidance.

# FLUIDS

Agilent offers NeoVac SY, Santovac 5 and Invoil 704 diffusion pump fluids in a variety of container sizes for your convenience.

	<b>NEOVAC SY</b>	<b>Invoil 704</b>	<b>SANTOVAC 5**</b>
Chemical description	Synthetic hydrocarbon	Single-component silicone	Mixed 5-ring polyphenyl ether
Chemical composition	Mono-N alkyldiphenylether	Tetramethyltetraphenyl trisiloxane	Mixed 5-ring polyphenyl Ether
Ultimate pressure Untrapped (Torr)	Low $10^{-8}$ range	$10^{-7}$ to $10^{-8}$ range	$10^{-10}$
Trapped (Torr)	$1 \times 10^{-11}$ range	to $10^{-11}$ range	–
Vapor pressure at 25 °C (Torr)	$1 \times 10^{-8}$	$2 \times 10^{-8}$	$1 \times 10^{-9}$ at 20 °C
Viscosity (cst) at 25 °C	25 at 40 °C	38	2400
Average molecular weight	405	484	446
Boiling temperature (°C) at 0.5 Torr	220 at 0.8 Torr	210	275
Flash point	230	221	288
Ultimate pressure	Very good	Very good	Excellent
Thermal stability	Good	Excellent	Very good
Oxidation resistance	Good	Excellent	Very good
System cleanliness	Very good	Very good	Excellent

\* Santovac 5 is the only recommended fluid for leak detectors.

**NEOVAC SY** is a high quality, low cost synthetic organic compound (alkyldiphenylether). With its low vapor pressure, it will achieve base pressures in the low  $10^{-8}$  Torr range untrapped and will not produce inorganic deposits which can cause electrostatic charge buildup on electrodes of sensitive instruments.

**Invoil 704** is a silicone oil with low vapor pressure and great thermal stability, making it desirable in processes such as vacuum coating, metallurgical work, and various other applications. It offers superior vapor pressure capabilities

and quick pump down cycles. With its low vapor pressure, it combines very good pumping characteristics with low Backstreaming Rates.

**Santovac 5** is a five-ring polyphenylether for use in ultrahigh vacuum applications. With ultra low vapor pressure and backstreaming rates, this fluid is very clean and often eliminates the need for traps and baffles. Ultimate pressures in the  $10^{-10}$  Torr range can be achieved and will not produce inorganic deposits which can cause electrostatic charge buildup on electrodes of sensitive instruments.

## Ordering Information

Description	Diffusion Pump Exact Charge	Weight kg (lbs)	Part Number
<b>NEOVAC SY</b>			
1 liter/1,000 cc	VHS-10, VHS-400	3.0 (1.4)	K6948301
U.S. gallon (3.8 liters)		10.6 (4.8)	K6948305
5 U.S. gallons (18.9 liters)		53.0 (23.9)	K6948315
<b>Santovac 5</b>			
40 cc		1.0 (0.5)	695405001
65 cc		2.0 (0.9)	695405002
500 cc	VHS-6, VHS-250	2.5 (1.1)	695405005
<b>Invoil 704</b>	Please ask Agilent for details		

## BAFFLES

### ▶ Extended Cold Caps for VHS-4, -6, and -10 Diffusion Pumps

The Extended Cold Cap is an option that fits inside the VHS-4, VHS-6, and VHS-10 pumps in place of the standard cold cap. It stops backstreaming as effectively as an optically dense baffle, yet it retains 80% of the pump's speed. Residual backstreaming is so low that it cannot be measured by the American Vacuum Society's standard collection method.

#### Technical Specifications

Speed with Extended Cold Cap	≈ 80% of pump speed
Materials	Nickel-plated copper
Cooling	Conduction (no water)

#### Ordering Information

Description	Weight kg (lbs)	Part Number
VHS-4	0.5 (1.0)	F6898301
VHS-6	0.5 (1.0)	F6455001
VHS-10	0.9 (2.0)	L8917301



### ▶ Halo Baffles for Large Diffusion Pumps for HS-16, -20, -32 and NHS-35 Diffusion Pumps

Agilent's Halo Baffles provide nearly twice the speed at the pump inlet as that achieved with conventional chevron baffles, while adding no height to the system. These water-cooled baffles are very economical compared to other opaque chevron baffles.

#### Technical Specifications

Net speed with Halo Baffle	Approximately 60% of pump speed*
Backstreaming reduction	Approximately 90%*
Materials	Nickel-plated copper (16 in., 20 in.)  Nickel-plated mild steel (32 in., 35 in.)
Cooling: recommended Water flow	In series with diffusion pumps; see specific diffusion pump technical specs HS16 – NHS-35

#### Ordering Information

Baffle Size	Weight kg (lbs)	Part Number
16 in.	9.0 (20.0)	K0143316
20 in.	11.0 (25.0)	K1855320
32 in.	16.0 (35.0)	K1856332
35 in.	20.0 (45.0)	K1857335

\* Values are estimates. Actual speed and backstreaming rate will vary depending on the application conditions.



## TECHNICAL NOTES

Diffusion pumps were first conceived and constructed by W. Gaede (1915-Germany) and I. Langmuir (1916-U.S.A). They operate on the principle of transferring momentum from high velocity vapor molecules to the gas molecules that are to be moved out of the system. The vapor molecules are formed by heating a suitable condensable fluid. The early pumps used mercury for this purpose.

In the late 1920s, C.R. Burch (England) and K.C. Hickman (U.S.A.) found that certain high molecular weight oils having high boiling points and low vapor pressures could be used as pumping fluids. These oils were useful because they remained in the pump indefinitely and allowed lower pressures to be attained without the use of a cold trap (see section on Baffles and Traps). Today, with the exception of a few isolated applications like some analytical instruments, all diffusion pumps use some form of oil. For additional information in this area, see the discussion on pumping fluids below.

As industrial and scientific requirements for rarefied atmospheres increased, research and development into the nature and production of high vacuum increased. By the early 1940s, a well-developed vacuum technology existed and was intensified both during World War II and by the space effort of the 1960s. Engineering has continued in the vacuum field, and in 1965 Agilent's M.H. Hablanian, et al. made a significant contribution to diffusion pump design that markedly increased pumping speeds.

### Applications

Due to its simplicity, high performance, and low initial cost, the diffusion pump remains a primary industrial high vacuum pumping mechanism. Applications for this type of pump are found in such diverse areas as:

1. Analytical instruments
2. Coating, functional
3. Coating, ornamental
4. Electron tube manufacture
5. Metallurgy
6. Optics
7. Outer space simulation
8. Particle accelerators
9. Petrochemicals
10. Pharmaceuticals
11. R&D laboratories
12. Semiconductor manufacture

Used in combination with the proper choice of motive fluids, traps, baffles, and valves, diffusion pumps can be used in a wide variety of applications and over pressure ranges from  $1 \times 10^{-3}$  Torr to  $2 \times 10^{-11}$  Torr.

### Basic Performance Factors

1. Pumping speed is volume per unit time. It is generally specified in liters/second and is an important parameter in determining the ultimate pressure of a system.

This is expressed by the relationship

$$Q = PS$$

Where:

Q is the system gas load in Torr-liters/second

P is the attainable pressure in Torr

S is the effective pump speed at the system

"Q" is the total leakage of the system which includes vapors given off by dirt and outgassing of internal surfaces as well as holes to the outside world. Ultimate pressure is also affected by such factors as the compression ratio for light gases and the nature of the pumping fluid.

2. **Maximum throughput** is the pump's maximum gas mass transfer capability – pressure x volume per unit time. It is generally specified in Torr-liters/second or mbar l/s.
3. **Tolerable forepressure** is the maximum allowable pressure in the foreline. It is maintained at or below this value by a suitably-sized mechanical foreline (backing) pump. If this pressure increases above that specified for a given pump, gas will diffuse back through the pump and pumping will stop. It should be noted that the size of this mechanical pump can affect the maximum throughput value.
4. **Backstreaming rate** is the rate at which the pumping fluid vapor leaves the inlet opening of the pump, moving back in the direction of the system being pumped. It is measured in milligrams per  $\text{cm}^2$  per unit time and will vary with the type of motive fluid employed.

### Operation

Diffusion pumps are vapor jet pumps that work on the basis of momentum transfer from a heavy high speed vapor molecule to a gas molecule. This results in the gas molecules being moved through the pump.

In Figure 1, the bottom of the pump contains an electric heater that is used to produce the vapor by heating the pumping (motive) fluid to its boiling point at reduced pressure.

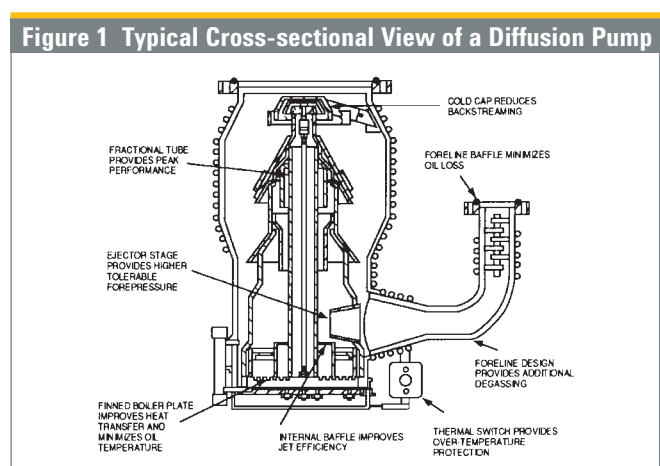



# DIFFUSION PUMPS

This means that before the pump is started, it must be “rough pumped” down to and held at an acceptable pressure, typically 10<sup>-1</sup> Torr. (For information on rough pumping, see section on Primary Pumps.) To do otherwise will result in no pumping action and possible damage to the pumping fluids. Once boiling of the fluid has begun, the vapor is forced up the central columns of the jet assembly. It then exits at each downward-directed jet in the form of a molecular curtain that impacts the water-cooled pump body. Here, the vapor condenses and runs back down to the boiler. This refluxing action continues as long as proper heat and forepressure are maintained.

As gas molecules from the system randomly enter the pump (molecular flow conditions), they encounter the top jet. Some of them are correctly impacted and driven on to the next jet. Subsequently, they reach the foreline where they are exhausted to the atmosphere by the mechanical backing pump.

The diffusion pump is similar in character to other compression pumps in that it develops a relatively high exhaust pressure compared to the inlet pressure. This compression ratio for an inlet pressure of 2 x 10<sup>-7</sup> Torr and a foreline pressure of 2 x 10<sup>-1</sup> would be ten million to one for most gases. Figure 2 shows how the pumping speed varies with pressure. Note that the speed remains constant from the 10<sup>-3</sup> Torr scale to the X<sup>-10</sup> Torr scale and then falls off as a result of the compression ratio for hydrogen and helium plus the vapor pressure contribution of the pumping fluid.

In the same way that the pump must be rough pumped before starting, so must the system to be evacuated by rough pumping prior to exposure to the pump. Exposing a hot pump to a rush of air at atmospheric pressure could be catastrophic for the equipment and possibly explosive, depending upon the

pump fluid being used. For further information in this area, see the discussion on pumping fluids, below.

## Design Features

Design features unique to Agilent diffusion pumps provide positive benefits to the customer, such as:

1. Agilent oil diffusion pumps incorporate an ejector stage as well as the full fractionation jets. This feature assures the user of constantly purified pumping fluid and the capability of maintaining low pressures.
2. Agilent oil diffusion pumps incorporate insulated jet drip shields which prevent re-boiling of oil droplets outside the jet assembly. This feature assures the user of the lowest backstreaming rates attainable.
3. Agilent water cooling coils are attached by a proprietary weld/brace technique. This special technique means excellent thermal contact and no chance for coils to “melt” away from the pump body in cases of accidental overheating.
4. Agilent pumps incorporate a water-cooled cold cap that reduces 98 percent of the backstreaming common to most diffusion pumps and the user is assured of a cleaner system.
5. Agilent water-cooled pumps incorporate the quick cool boiler coils, allowing faster shutdown of the system with no damage to the oil.
6. Agilent pumps use standard ASA flanges. This feature permits wide flexibility formatting with systems and other hardware.
7. Agilent (4-inch and larger) pumps have a thermal protection switch as a standard feature. This device prevents damage to the pump and surroundings due to overheating.

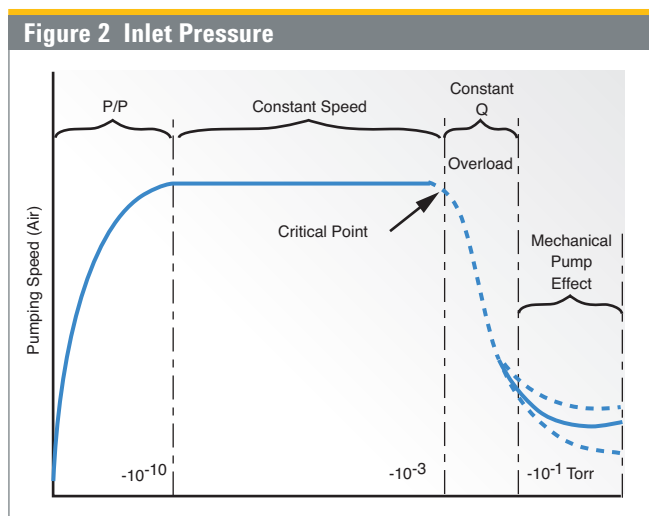

Typical plot of diffusion pump performance. Four regions are evident: 1) Effect of the pressure ratio limit; 2) Normal operating range with constant speed; 3) Throughput limited condition; 4) Effect of backing pump.

## Pumping Fluids

In an oil diffusion pump, high speed heated oil vapor provides the kinetic energy that moves gas molecules to the foreline and prevents their back-migration. These oils may be derived from a petroleum base but more typically are synthesized from phthalates, sebacates, phenyl groups, or siloxanes.

To be an effective pumping fluid, the compound must have a relatively high molecular weight and a low vapor pressure at elevated temperatures. Other desirable properties are inertness and stability in order to resist chemical reaction and disintegration into undesirable fractions.

Phenyl ethers such as Neovac-SY and Santovac-5 are fairly resistant to oxidation and are used successfully around electronic devices. These oils polymerize into a conducting film when bombarded with electrons and thus do not promote static charge build-up. In addition, they are quite soluble and “clean up” easily. Neovac-SY has the advantage of economy while Santovac-5 is more durable and has a lower vapor pressure.

## TECHNICAL NOTES

For additional oxidation resistance, many applications lend themselves to the use of silicone fluids. These are phenyl siloxane compounds that polymerize as a non-conducting film that can allow static charge build-up and are difficult to clean up. There are many silicone fluids on the market, so Agilent recommends using those equivalent to Invoil 704 (see page 156) or their variants, depending on application. Another extremely stable fluid under reactive conditions is the fluorinated polyphenyl ether (Fomblin® or Krytox). This oil is widely used in mechanical oil-sealed pumps where large amounts of oxygen are pumped. It is also suitable as a diffusion pump fluid where large quantities of oxygen or other reactive gases may be encountered.

### Speed Measurements

**Note:** *The speed values in this catalog have been measured according to ISO Standard 1608/1. They differ from the values published in previous catalog editions strictly due to the change in testing methods. The design and performance of the pumps have not changed in any way – only the speed test method.*

*For reference, the speed values from the previous catalog editions are included in the technical specifications table for each pump. The data is labeled “Pumping Speed”, AVS 4.1 (1963).*

*The pressure gage mounted in the test dome is located at a distance of 1/2 the diameter of the pump from the inlet plane, versus 1/4 the diameter in previous tests. Also, total pressure gages were used to measure the pressure and calculate speed, versus partial pressure gages.*

*Combined, these two changes in test method result in a measured speed approximately 40% lower than previously published values. The changes in test method do not affect maximum throughput measurements.*

Pumping speed is measured by introducing a known, steady state flow of gas into a measuring dome of specified geometry and measuring the resulting pressure established in the dome. Figure 1 shows the experimental setup used by Agilent as recommended by the American Vacuum Society (Standard 4.1). Speed is determined by the AVS Standard as:

$$S = Q / (P - P_0),$$

where Q is the flow rate (throughput) and P<sub>0</sub> is the ultimate pressure prior to the experiment. All diffusion pump curves shown in the catalog are based on the use of DC704 diffusion pump fluid and the standard cold cap (unless otherwise noted). The speed curves are created by calculating the speed at increasing levels of gas throughput, allowing time between readings to ensure steady state conditions are reached.

Diffusion pumps exhibit different speeds for different gases. Thus, the speed of each gas is obtained by dividing the throughput of the gas by the partial pressure of the same gas in the dome. Unless otherwise noted, the speeds shown in this catalog are for air.

Measuring the speed of a diffusion pump installed in a vacuum system often gives different results since the geometry, surface area, construction materials, and most importantly, pressure measurement locations differ from the measuring dome.

### Backstreaming Measurements

Primary backstreaming can be measured by relatively simple means for pumps without baffles or traps. AVS Standard 4.5 (Journal of Vacuum Science and Technology, Volume 8, Number 5.) recommends the test dome configuration shown in Figure 2. The backstreaming rates published in Agilent’s catalog are measured using this technique. Any molecules which cross the pump inlet in the upward direction and condense in the dome may be said to be backstreaming.

The condensed pumping fluid collects in the trough around the periphery of the dome and drains into a measuring tube. Usually, it takes several days to collect sufficient fluid for satisfactory measurements. Regular volumetric measurements are taken and recorded on a volume versus time graph until the rate is observed to be steady ( $\pm 10\%$ ) for at least 72 hours. The backstreaming rate is the average slope of the Volume-Time curve in the 72 hour time period. Note that this test will ignore “spikes” in the backstreaming rate, which may occur during startup, since only the volume collected during the steady-state, 72-hour

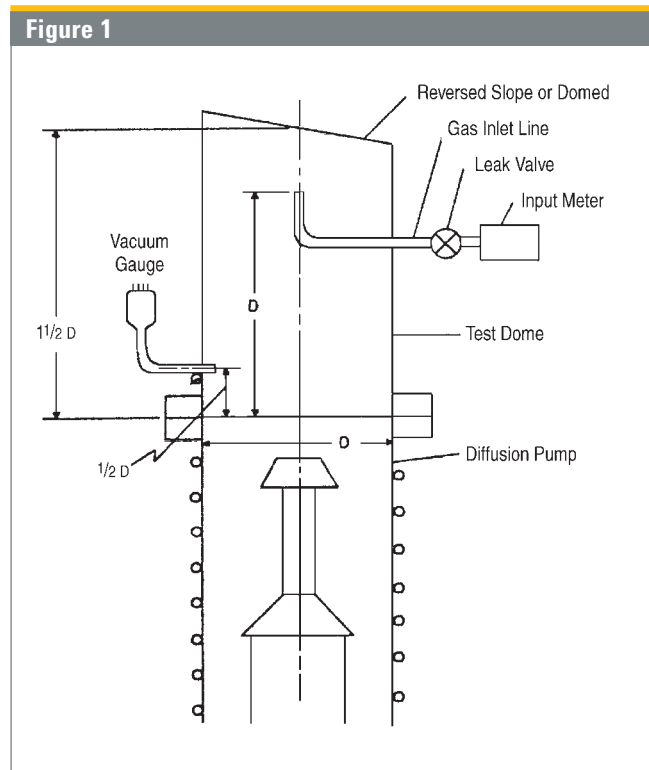

# DIFFUSION PUMPS

period is considered. All backstreaming tests were performed using DC-704 pumping fluid (no longer available).

The measured backstreaming rate is very dependent on the test method used. If any method other than the dome method described above is used, the results can differ significantly from published values. Note also that the reported backstreaming values are valid for the normal operating range of the pump, at a pressure well below the point at which the top jet starts to break down (i.e. below the “knee” of the speed curve, where the speed is no longer constant with pressure). Above this critical pressure the backstreaming rate may rise markedly.

Backstreaming measurements above the baffle cannot be made with the standard test apparatus. The rates are so low that the collecting surfaces must be refrigerated to prevent re-evaporation, and the collection surface must be designed to collect smaller amounts of fluid.

## Using Baffles to Reduce Backstreaming

If the vacuum system has intolerance to backstreaming, a baffle or trap should be considered. Too often a system designer will forego the use of baffles to reduce system cost, only to find the normal amount of backstreaming from the diffusion pumps is too high for the application. This is usually the case for high quality coating applications. The choice of baffle type is a trade-off between backstreaming level, net

pumping speed, size, and cost. The designer can choose a water-cooled halo baffle, water-cooled optically dense baffle, or a cryotrap. A diffusion pump can be ordered with a cold cap or a halo baffle (which has an integral cold cap). If an external baffle is to be used, the diffusion pump is typically ordered with a cold cap.

A water-cooled halo baffle is designed to intercept a majority of the primary backstreaming which escapes the cold cap. A cooled ring, or halo, is strategically placed where most of the backstreaming occurs. The rate is reduced by approximately 90% with a corresponding reduction in speed of roughly 40%. The actual reduction in backstreaming and speed depends on the type of pump and the application conditions. A water-cooled, optically tight baffle is designed to intercept 100% of the primary backstreaming, so what remains is secondary backstreaming. The temperature of the baffle surface, rather than the baffle geometry, determines the secondary backstreaming rate. Thus the choice of baffle becomes a trade-off between size (height), conductance, and cost.

A cryotrap, or liquid nitrogen trap, has a liquid nitrogen reservoir and various baffling surfaces. The reservoir is insulated from the environment by an evacuated space. The LN2 boils off to atmosphere through a vent port. Since LN2 boils at  $-196\text{ }^{\circ}\text{C}$ , the trap’s internal surfaces are extremely cold. In systems with liquid nitrogen traps, the backstreaming level can be controlled at such a low level that contaminants from sources other than the diffusion pump will predominate.

## Estimating the Effect a Baffle Has on the Speed of the Pump

The degree to which a baffle will reduce the effective pumping speed of a diffusion pump depends on its conductance, which is a function of its geometry. Manufacturers either publish conductance values in L/s or provide an estimate of the retained pumping speed (e.g. “Retains 50% of pumping speed”). When a conductance value for the baffle,  $C_{\text{baffle}}$ , is published, an estimate of the effective pumping speed,  $S_{\text{eff}}$ , is given by:

$$S_{\text{eff}} = (C_{\text{baffle}} * S_{\text{pump}}) / (C_{\text{baffle}} + S_{\text{pump}})$$

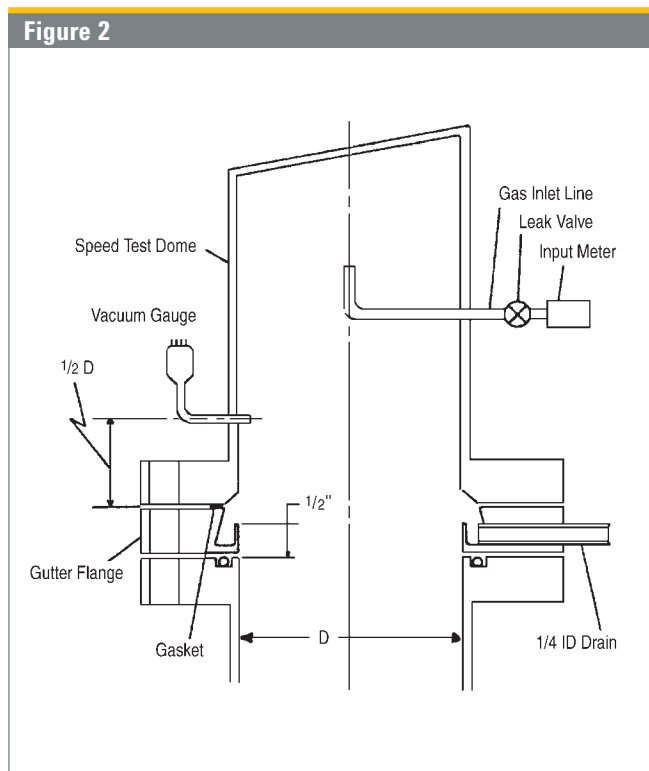

**По вопросам продаж и поддержки обращайтесь:**

Алматы (7273)495-231	Казань (843)206-01-48	Новокузнецк (3843)20-46-81	Смоленск (4812)29-41-54
Архангельск (8182)63-90-72	Калининград (4012)72-03-81	Новосибирск (383)227-86-73	Сочи (862)225-72-31
Астрахань (8512)99-46-04	Калуга (4842)92-23-67	Омск (3812)21-46-40	Ставрополь (8652)20-65-13
Барнаул (3852)73-04-60	Кемерово (3842)65-04-62	Орел (4862)44-53-42	Сургут (3462)77-98-35
Белгород (4722)40-23-64	Киров (8332)68-02-04	Оренбург (3532)37-68-04	Тверь (4822)63-31-35
Брянск (4832)59-03-52	Краснодар (861)203-40-90	Пенза (8412)22-31-16	Томск (3822)98-41-53
Владивосток (423)249-28-31	Красноярск (391)204-63-61	Пермь (342)205-81-47	Тула (4872)74-02-29
Волгоград (844)278-03-48	Курск (4712)77-13-04	Ростов-на-Дону (863)308-18-15	Тюмень (3452)66-21-18
Вологда (8172)26-41-59	Липецк (4742)52-20-81	Рязань (4912)46-61-64	Ульяновск (8422)24-23-59
Воронеж (473)204-51-73	Магнитогорск (3519)55-03-13	Самара (846)206-03-16	Уфа (347)229-48-12
Екатеринбург (343)384-55-89	Москва (495)268-04-70	Санкт-Петербург (812)309-46-40	Хабаровск (4212)92-98-04
Иваново (4932)77-34-06	Мурманск (8152)59-64-93	Саратов (845)249-38-78	Челябинск (351)202-03-61
Ижевск (3412)26-03-58	Набережные Челны (8552)20-53-41	Севастополь (8692)22-31-93	Череповец (8202)49-02-64
Иркутск (395)279-98-46	Нижний Новгород (831)429-08-12	Симферополь (3652)67-13-56	Ярославль (4852)69-52-93
Россия (495)268-04-70	Киргизия (996)312-96-26-47	Казахстан (7172)727-132	

[afr@nt-rt.ru](mailto:afr@nt-rt.ru) || <https://agilent.nt-rt.ru/>