

RP RPS

Технические характеристики

По вопросам продаж и поддержки обращайтесь:

Алматы (7273)495-231
Архангельск (8182)63-90-72
Астрахань (8512)99-46-04
Барнаул (3852)73-04-60
Белгород (4722)40-23-64
Брянск (4832)59-03-52
Владивосток (423)249-28-31
Волгоград (844)278-03-48
Вологда (8172)26-41-59
Воронеж (473)204-51-73
Екатеринбург (343)384-55-89
Иваново (4932)77-34-06
Ижевск (3412)26-03-58
Иркутск (395)279-98-46
Россия (495)268-04-70

Казань (843)206-01-48
Калининград (4012)72-03-81
Калуга (4842)92-23-67
Кемерово (3842)65-04-62
Киров (8332)68-02-04
Краснодар (861)203-40-90
Красноярск (391)204-63-61
Курск (4712)77-13-04
Липецк (4742)52-20-81
Магнитогорск (3519)55-03-13
Москва (495)268-04-70
Мурманск (8152)59-64-93
Набережные Челны (8552)20-53-41
Нижний Новгород (831)429-08-12
Киргизия (996)312-96-26-47

Новокузнецк (3843)20-46-81
Новосибирск (383)227-86-73
Омск (3812)21-46-40
Орел (4862)44-53-42
Оренбург (3532)37-68-04
Пенза (8412)22-31-16
Пермь (342)205-81-47
Ростов-на-Дону (863)308-18-15
Рязань (4912)46-61-64
Самара (846)206-03-16
Санкт-Петербург (812)309-46-40
Саратов (845)249-38-78
Севастополь (8692)22-31-93
Симферополь (3652)67-13-56
Казахстан (7172)727-132

Смоленск (4812)29-41-54
Сочи (862)225-72-31
Ставрополь (8652)20-65-13
Сургут (3462)77-98-35
Тверь (4822)63-31-35
Томск (3822)98-41-53
Тула (4872)74-02-29
Тюмень (3452)66-21-18
Ульяновск (8422)24-23-59
Уфа (347)229-48-12
Хабаровск (4212)92-98-04
Челябинск (351)202-03-61
Череповец (8202)49-02-64
Ярославль (4852)69-52-93

MS-SERIES ROTARY VANE PUMPS FEATURES AND BENEFITS

Agilent: a complete solution provider for the industrial vacuum equipment

Agilent MS-Series high capacity mono stage oil lubricated rotary vane pumps, from 95 to 680 m³/h.

- MS-Series pumps are robust, easy to install, and are ideal for use in many different applications
- Because of their compact size, MS-Series pumps can easily replace other pumps of equivalent pumping speed

**Industry leading vacuum performance;
more than 20,000 RV pumps in operation!**

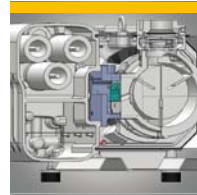

Shorter Cycle Times

- Smooth continuous operation, from atmospheric to base pressure
- High pumping speed even at low pressure

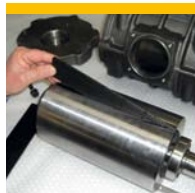

Highly Robust for Stringent Applications

- Steel rotor
- Cast iron stator and cover
- Special design carbon fiber vanes
- Viton seals
- Gas ballast valve, for pumping high water vapor content
- Anti-suckback isolation inlet valve eliminates oil backstreaming and holds vacuum in case of power loss

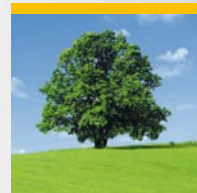

Environmentally Friendly

- A demister system limits oil exhaust over the entire range of working pressures
- Floating valve for oil recovery

HIGH CAPACITY MS-RPS SERIES



Industry Leading Vacuum Performance

- Pump design allows lowest base partial pressure: 8×10^{-2} mbar (6×10^{-2} Torr)

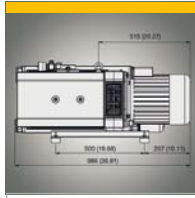

Compact and Easy to Install

- Air cooling
 - cover design optimizes cooling air channels
 - integrated heat exchanger carries excess heat away
- Smaller than pumps of equivalent pumping speed

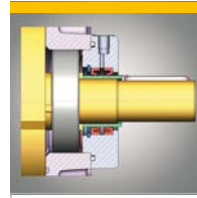

Highly Reliable

- Highly efficient oil circulation system ensures perfect lubrication and sealing in all critical areas of the pump
- Low noise and vibration



RPS-SERIES ROOTS PUMPS & PUMPING SYSTEMS (FEATURES AND BENEFITS)

RP-Series Roots Pumps

State-of-the-art, high performance Agilent Roots Pumps are ideal for use in demanding industrial applications.

RPS-Series Roots Pumping Systems

Agilent's RPS Systems combine the ruggedness and reliability of High Capacity MS-Series RVPs with wide range Roots Pumps.

More than 15,000 Roots Pumps in Operation!

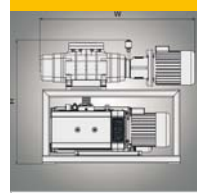

Compact and Easy to Use

- Agilent Roots Pumps are simple to use and to install
- Air cooling



Designed for Optimum System Integration

- Ideal combination for roughing down and backing Diffusion Pumps, Turbomolecular Pumps, and other HV pumps
- Optional electronics for continuous operation and monitoring of Vacuum Systems



Clean

Ideal for use in applications demanding the highest levels of cleanliness:

- Special labyrinth seal prevents contamination
- A high capacity trap chamber captures condensation



VFD Roots

- Inverter driven Roots to improve performance and minimize power consumption
- Constant performance at different input frequencies

HIGH CAPACITY MS-RPS SERIES



High Performance Roots Pumps

- Agilent Roots Pumps can withstand high mechanical loads reducing pumpdown cycles
- Lowest base pressure:
 5×10^{-3} mbar (4×10^{-3} Torr)

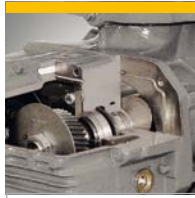

Rugged and Reliable

- Low noise and vibration, thanks to dynamically balanced rotors and precision ground gears
- Long maintenance intervals
- Air cooling



Popular Sizes Available

- Combining MS-Series RVPs (from 95 to 680 m³/h) and Roots Pumps (from 250 to 4000 m³/h) allows tailored solutions optimizing performances, cost and power consumption

Other combinations are available on request.

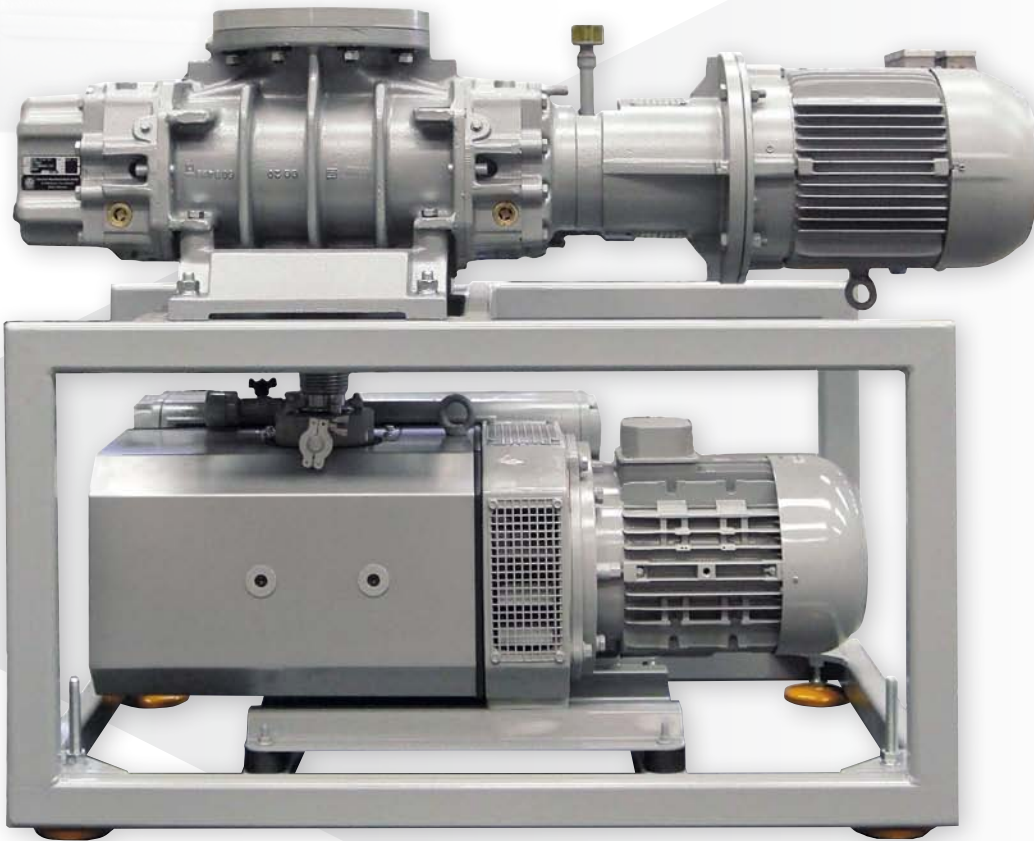

TYPICAL APPLICATIONS



Roughing and Backing High Vacuum Pumps

The new MS Pumps and RPS Systems are ideally suited for use in combination with Turbomolecular and Diffusion pumps or with HV pumps of any other manufacturer.

Agilent is a leading solution provider for the industrial high and medium vacuum marketplace.



Vacuum Coating Systems

The most common application where the RPS are used are coaters of different dimensions, from small ones used in research fields to the very large ones used in industrial applications, including for instance glass coaters or coaters where large automotive or aircraft parts are treated. The ability to offer large RV pumps, up to 680 m³/h and Roots pumps up to 4000 m³/h make the Agilent offer in this range particularly interesting and able to satisfy different needs.

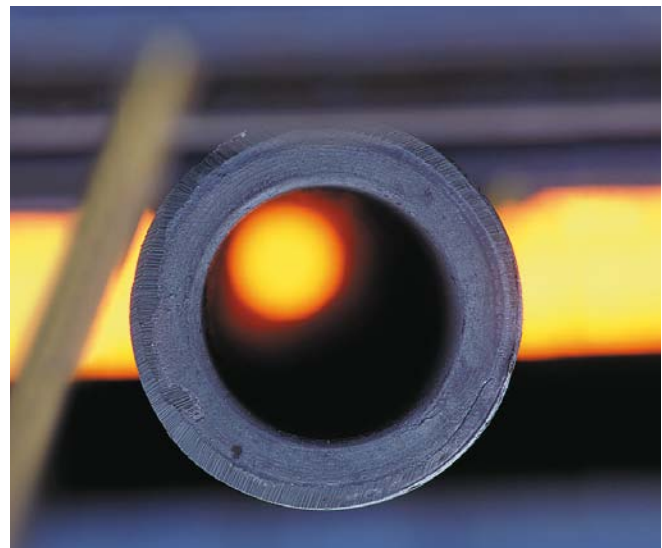

Metallurgy and Heat Treatment

In this field Agilent has offered so far a very large number of Diffusion pumps, with sizes ranging up to 35,000 l/s. The availability now to provide the full vacuum system up to the atmospheric pressure is rapidly bringing this offer to satisfy most of the users, who are particularly interested in rapid cycle times and the excellent overall reliability of the Agilent solution.

HIGH CAPACITY MS-RPS SERIES



Helium Leak Detection

When large volumes or short cycle times are required for a process involving leak detection, typically but not only using helium, the Agilent RV pumps alone or in combination with the Roots pumps are an ideal solution to reach the parameters necessary for industrial applications. Agilent is well aware of technical aspects of this technology having been a pioneer in leak detection for several decades.



Electron Beam Welding

EBW equipment requires the use of both High Vacuum Pumps, during generation and running of the welding beam, and Medium Vacuum Pumps for the rest of the process taking place in the chamber where the parts to be welded are positioned. Thanks to the introduction of the new Roots Pumping Systems, today Agilent is in a position to offer the entire vacuum system, as a single supply source in this important industry.



LNG

Liquefied Natural Gas (LNG) is natural gas converted to liquid form for ease of storage or transport. LNG must be kept cold to remain a liquid, independent of pressure. For this reason it must be stored in vacuum-jacketed, cryogenic tanks pressure vessels. These tanks may be at pressures anywhere from less than 50 kPa to over 1,700 kPa (7 psig to 250 psig). Agilent Roots Pumping Systems, in combination with Agilent Diffusion Pumps, are ideal to create vacuum in the annular space of the cryogenic tanks.

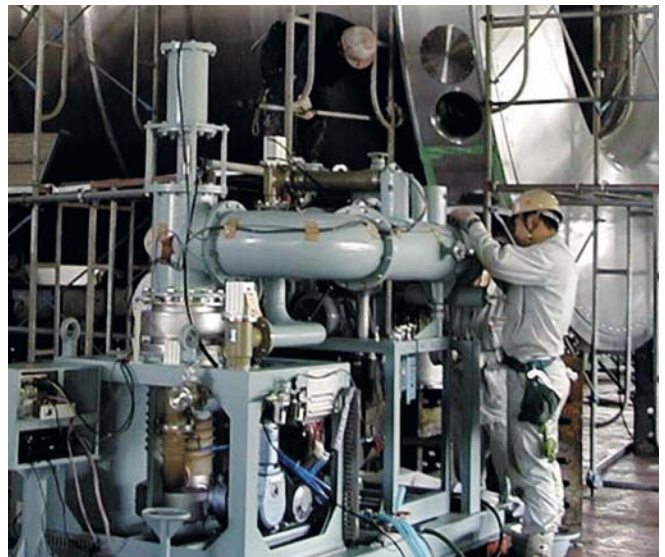

Other Industrial Applications

Agilent RV pumps and Roots Systems are suitable for use in many other applications, including lamps manufacturing, vacuum drying and degassing, gas recovery, packing industry, chemistry and process technology, PET processing, pharmaceutical industry, vacuum distillation, cryogenic vessel evacuation, and many others.

PUMP MODELS

▶ Agilent MS-101

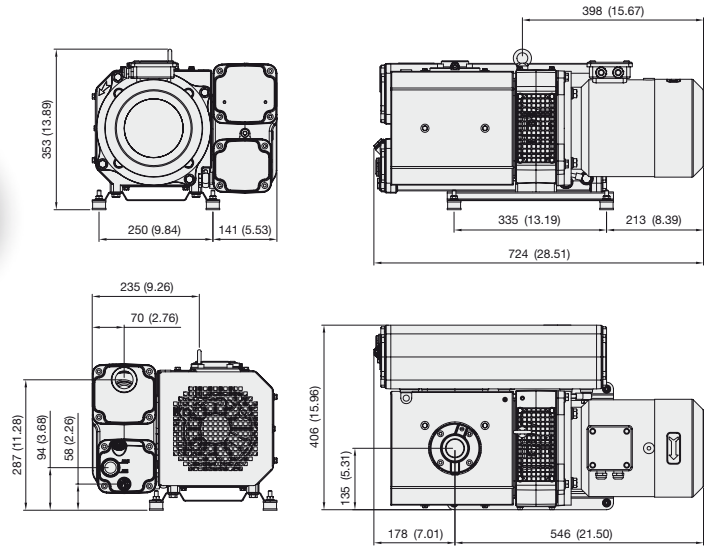

Dimensions: millimeters (inches)

Technical Specifications

Free air displacement	60 Hz: 130 m ³ /hr, 76 cfm 50 Hz: 110 m ³ /hr, 65 cfm
Pumping speed*	60 Hz: 109 m ³ /hr, 64 cfm 50 Hz: 95 m ³ /hr, 56 cfm
Ultimate partial pressure (with gas ballast closed)	≤ 0.1 mbar (≤ 8 × 10 ⁻² Torr)
Ultimate total pressure (with gas ballast open)	≤ 0.5 mbar (≤ 0.4 Torr)
Power	60 Hz: 3.0 kW (4.0 HP) 50 Hz: 2.2 kW (3.0 HP)
Electrical motor characteristics	IM B5 Δ230/Y400 V at 50 Hz IM B5 YY230/Y460 V at 60 Hz IM B5 Δ220/Y380 V at 60 Hz
Revolutions number	60 Hz: 1800 RPM 50 Hz: 1500 RPM
Water vapor tolerance	60 Hz/50 Hz: 40/30 mbar (30/23 Torr)
Water vapor capacity	60 Hz/50 Hz: 3/2.2 kg/h (3.3/2.4 qt/hr)
Noise level**	60 Hz/50 Hz: 68/66 dB(A)
Inlet port	1¼" gas / 1¼" NPT/ DN40KF using adapter flanges
Exhaust port	1¼" gas / 1¼" NPT
Oil	type MS-01, charge 3 liter (3.1 qt)
Working ambient temperature range	+12 +40 °C (+54 +105 F)
Storage temperature	-15 +70 °C (+5 +158 F)
Dimensions	60 Hz: 750 x 405 x 349 mm (20.5 x 15.9 x 13.7 in.) 50 Hz: 718 x 405 x 349 mm (28.3 x 15.9 x 13.7 in.)
Weight	
with 2.2 kW motor	85 kg (187 lbs)
with 3.0 kW motor	89 kg (196 lbs)
without motor	62 kg (137 lbs)

* According to PNEUROP 6602

** According to EN ISO 2151 (50/60 Hz)

HIGH CAPACITY MS-RPS SERIES

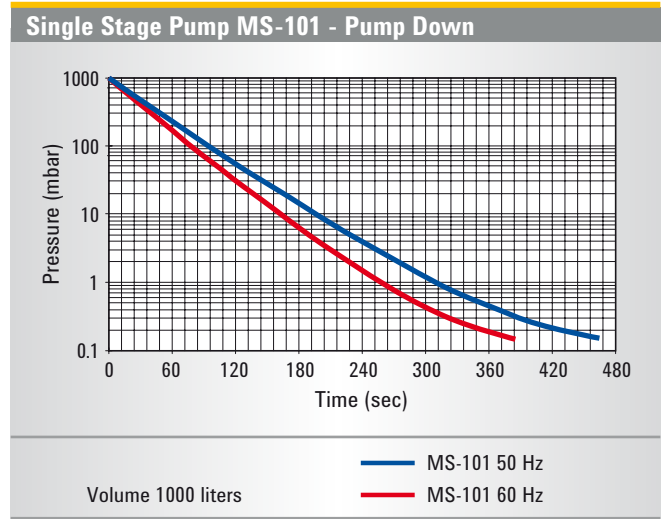
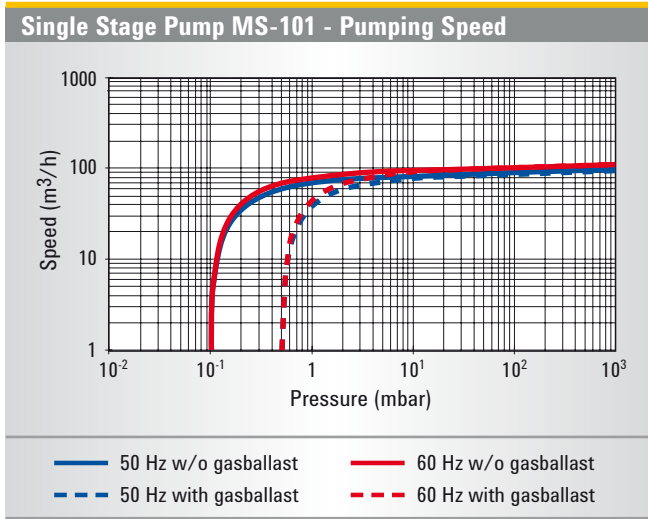

High Capacity MS-RPS Pumps

Ordering Information

High Capacity Rotary Vane Pumps *	Part Number
MS-101 2.2 kW Δ230/Y400 V, 50 Hz; IE2; inlet 1¼" gas	X3751-60019
MS-101 3.0 kW Δ230/Y400 V, 50 Hz; 460 V, 60 Hz; inlet 1¼" gas	X3751-64008
MS-101 3.0 kW Δ230/Y380 V, 60 Hz; IE2; inlet 1¼" gas	X3751-60026
MS-101 3.0 kW YY230/Y460 V, 60 Hz; IE2; inlet 1¼" NPT (US version)	X3751-60021

* Oil charge not included

Oil and Accessories	Part Number
MS-01 Oil charge for MS-101 (3 liters)	X3760-64001
Inlet air filter with polyester cartridge, for DN40 KF	X3751-60014
Inlet air filter with polyester cartridge, for 1¼" gas	X3751-60013
Inlet air filter with polyester cartridge, for 1¼" NPT	X3751-60030
Connection fitting kit, for DN40 KF	X3751-60016
Connection fitting kit, for for 1¼" gas	X3751-60015
Connection fitting kit, for 1¼" NPT	X3751-60031
Exhaust filter control pressure switch	9495077
1¼" gas to DN40 KF adapter	X3751-64009
1¼" NPT to DN40 KF adapter	X3751-64010

Spare Parts	Part Number
MS-101 minor spare part kit	X3751-60010
MS-101 major spare part kit	X3751-60011
MS-101 inlet air filter polyester cartridge	X3751-60017
MS-101 exhaust coalescent filter kit	X3751-60018

PUMP MODELS

▶ Agilent MS-301

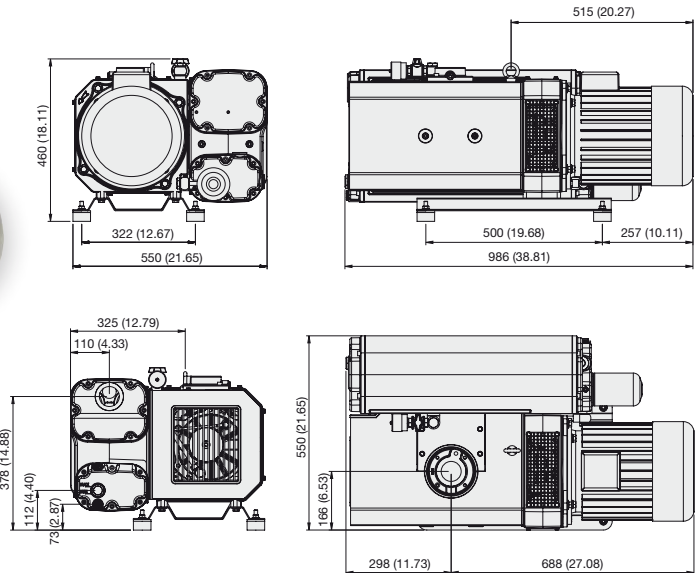

Dimensions: millimeters (inches)

Technical Specifications

Free air displacement	60 Hz: 350 m ³ /hr, 210 cfm 50 Hz: 290 m ³ /hr, 170 cfm
Pumping speed*	60 Hz: 290 m ³ /hr, 170 cfm 50 Hz: 250 m ³ /hr, 150 cfm
Ultimate partial pressure (with gas ballast closed)	≤ 8 × 10 ⁻² mbar (≤ 6 × 10 ⁻² Torr)
Ultimate total pressure (with gas ballast open)	≤ 0.5 mbar (≤ 0.37 Torr)
Power	60 Hz: 7.5 kW (10.0 HP) 50 Hz: 5.5 kW (7.4 HP)
Electrical motor characteristics	IM B5 Δ230/Y400 V at 50 Hz, Y460 V at 60 Hz IM B5 Δ400/Y690 V at 50 Hz, Δ460 V at 60 Hz IM B5 Δ220/Y380 V at 60 Hz IM B5 YY230/Y460 V at 60 Hz
Revolutions number	60 Hz: 1750 RPM 50 Hz: 1450 RPM
Water vapor tolerance	60 Hz/50 Hz: 40/30 mbar (30/23 Torr)
Water vapor capacity	60 Hz/50 Hz: 7/5 kg/h (7.7/5.5 qt/hr)
Noise level**	60 Hz/50 Hz: 76/72 dB(A)
Inlet port	Flange DN 63 ISO-K / 2" gas / 2" NPT
Exhaust port	2" gas / 2" NPT
Oil	type MS-01, charge 7 liter (7.4 qt)
Working ambient temperature range	+12 +40 °C (+54 +105 F)
Storage temperature	-20 +70 °C (+4 +158 F)
Dimensions	60 Hz: 1015 x 550 x 460 mm (40.3 x 21.6 x 18.1 in.) 50 Hz: 986 x 550 x 460 mm (38.8 x 21.6 x 18.1 in.)
Weight	
with 5.5 kW motor	188 kg (414 lbs)
with 7.5 kW motor	192 kg (423 lbs)
without motor	141 kg (310 lbs)

* According to PNEUROP 6602

** According to EN ISO 2151 (50/60 Hz)

HIGH CAPACITY MS-RPS SERIES

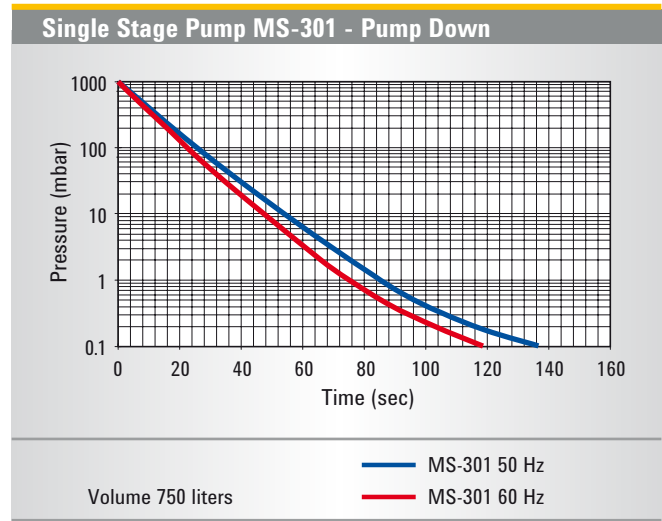
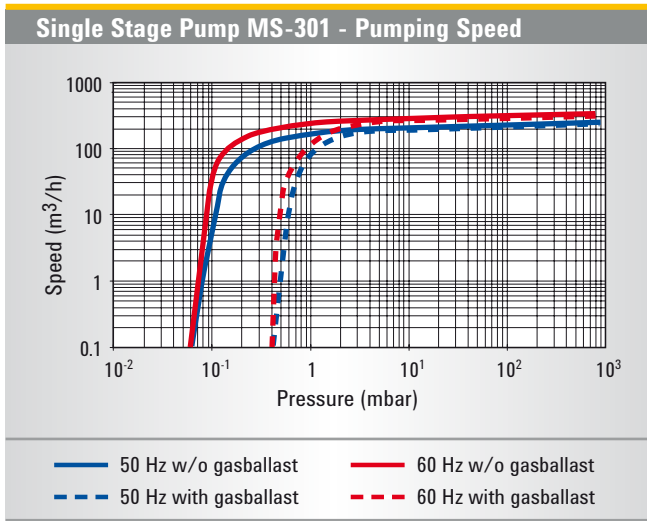

Ordering Information

High Capacity Rotary Vane Pumps *	Part Number
MS-301 5.5 kW, Δ230/Y400 V, 50 Hz; IE2; inlet 2" gas	X3752-64016
MS-301 5.5 kW, Δ230/Y400 V, 50 Hz; IE2; DN 63 ISO-K	X3752-64017
MS-301 5.5 kW, Δ400/Y690 V, 50 Hz; IE2; inlet 2" gas	X3752-64018
MS-301 5.5 kW, Δ400/Y690 V, 50 Hz; IE2; DN 63 ISO-K	X3752-64019
MS-301 7.5 kW, Δ230/Y400 V, 50 Hz - Y460 V 60 Hz; inlet 2" gas	X3752-64020
MS-301 7.5 kW, Δ230/Y400 V, 50 Hz - Y460 V 60 Hz; DN 63 ISO-K	X3752-64021
MS-301 7.5 kW, Δ230/Y380 V, 60 Hz; inlet 2" gas	X3752-64024
MS-301 7.5 kW, Δ230/Y380 V, 60 Hz; inlet DN 63 ISO-K	X3752-64025
MS-301 7.5 kW, YY230/Y460 V, 60Hz; inlet 2" NPT (US version)	X3752-64022
MS-301 7.5 kW, YY230/Y460 V, 60Hz; inlet DN 63 ISO-K (US version)	X3752-64023

* Oil charge not included

Oil and Accessories	Part Number
MS-01 Oil charge for MS-301 (7 liters)	X3760-64002
Inlet air filter with polyester cartridge, for 2" gas connection	9495059
Inlet air filter with polyester cartridge with DN 63 ISO-K flange	9495159
Connection fitting kit, for 2" gas connection	9495065
Connection fitting kit, for DN 63 ISO-K flange connection	9495165

Protective Accessories	Part Number
Pump thermal protection switch (to be ordered together with the pump)	9495076
Oil separator control pressure switch (to be ordered together with the pump)	9495077
MS-301 oil level protection switch (to be ordered together with the pump)	9495078

Spare Parts	Part Number
MS-301 minor spare part kit	9495020
MS-301 major spare part kit	9495021
Oil filter (type A)	9495070
MS-301 inlet air filter polyester cartridge	9495083
MS-301 exhaust coalescent filter kit	SR03706308

PUMP MODELS

▶ Agilent MS-631

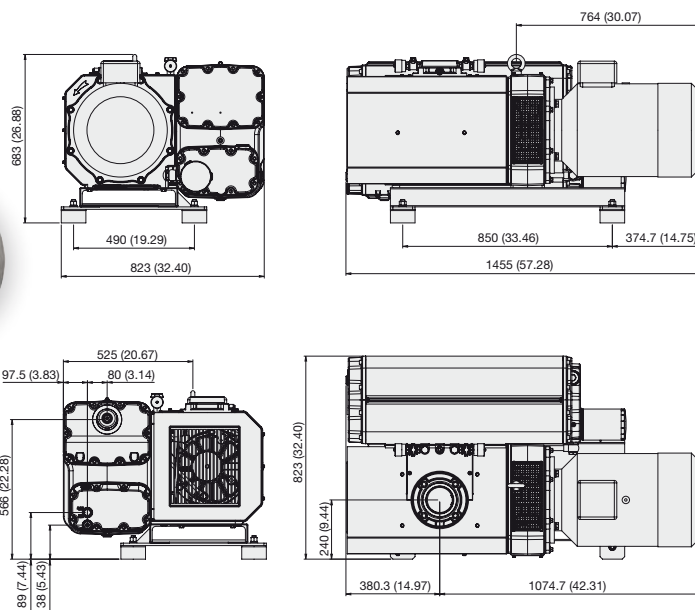

Dimensions: millimeters (inches)

Technical Specifications

Free air displacement	60 Hz: 790 m ³ /hr, 465 cfm 50 Hz: 660 m ³ /hr, 390 cfm
Pumping speed*	60 Hz: 680 m ³ /hr, 400 cfm 50 Hz: 590 m ³ /hr, 350 cfm
Ultimate partial pressure (with gas ballast closed)	≤ 8 x 10 ⁻² mbar (≤ 6 x 10 ⁻² Torr)
Ultimate total pressure (with gas ballast open)	≤ 0.5 mbar (≤ 0.37 Torr)
Power	60 Hz: 18.5 kW (24.8 HP) 50 Hz: 15 kW (20.1 HP)
Electrical motor characteristics	IM B5 Δ400/Y690 V at 50 Hz, Δ460 V at 60 Hz IM B5 Δ220/Y380 V at 60 Hz IM B5 YY230/Y460 V at 60 Hz
Revolutions number	60 Hz: 1200 RPM 50 Hz: 1000 RPM
Water vapor tolerance	60 Hz/50 Hz: 40/30 mbar (30/23 Torr)
Water vapor capacity	60 Hz/50 Hz: 30/20 kg/h (33.1/22.0 qt/hr)
Noise level**	60 Hz/50 Hz: 73/71 dB(A)
Inlet port	Flange DN 100 ISO-K / 4" gas / 4" NPT
Exhaust port	3" gas / 3" NPT
Oil	type MS-01, charge 22 liter (23.2 qt)
Working ambient temperature range	+12 +40 °C (+54 +105 F)
Storage temperature	-20 +70 °C (+4 +158 F)
Dimensions	60 Hz: 1480 x 823 x 683 mm (58.2 x 32.4 x 26.9 in.) 50 Hz: 1455 x 823 x 683 mm (57.3 x 32.4 x 26.9 in.)
Weight	
with 15.0 kW motor	582 kg (1283 lbs)
with 18.5 kW motor	612 kg (1349 lbs)
without motor	392 kg (864 lbs)

* According to PNEUROP 6602

** According to EN ISO 2151 (50/60 Hz)

HIGH CAPACITY MS-RPS SERIES

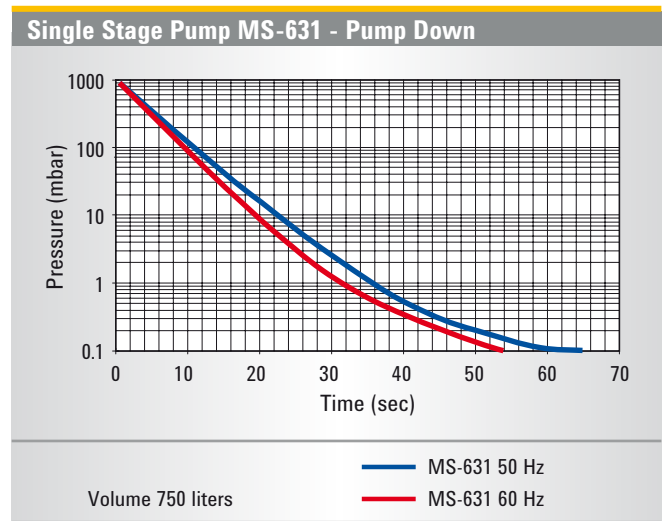
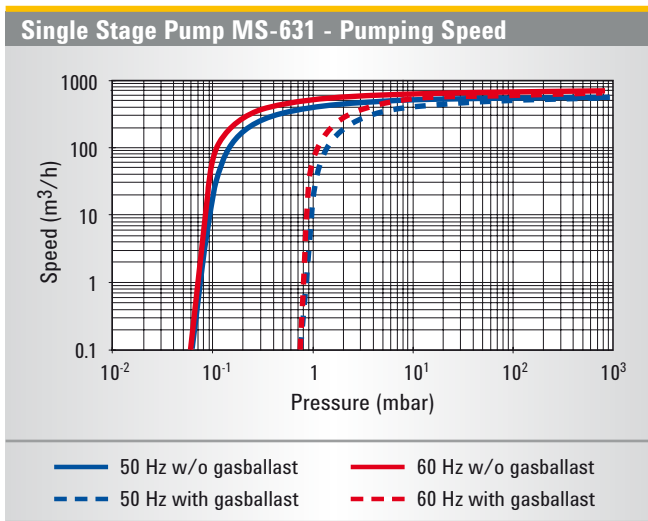

High Capacity
MS-RPS Pumps

Ordering Information

High Capacity Rotary Vane Pumps *	Part Number
MS-631 15.0 kW, Δ400/Y690 V, 50 Hz; IE2; inlet 4" gas	X3753-64073
MS-631 15.0 kW, Δ400/Y690 V, 50 Hz; IE2 DN 100 ISO-K	X3753-64074
MS-631 15.0 kW, Δ400/Y690 V, 50 Hz - Δ460 V, 60 Hz; inlet 4" gas	X3753-64075
MS-631 18.5 kW, Δ400/Y690 V, 50 Hz - Δ460 V, 60 Hz; DN 100 ISO-K	X3753-64076
MS-631 18.5 kW, Δ220/Y380 V, 60 Hz; IE2; inlet 4" gas	X3753-64079
MS-631 18.5 kW, Δ220/Y380 V, 60 Hz; IE2; DN 100 ISO-K	X3753-64080
MS-631 18.5 kW, YY230/Y460 V, 60 Hz; IE2; inlet 4" gas	X3753-64077
MS-631 18.5 kW, YY230/Y460 V, 60 Hz; IE2; DN 100 ISO-K	X3753-64078

* Oil charge not included

Oil and Accessories	Part Number
MS-01 Oil charge for MS-631 (22 liters)	X3760-64003
Inlet air filter with polyester cartridge, for 4" gas connection	9495062
Inlet air filter with polyester cartridge with DN 100 ISO-K flange	9495162
Connection fitting kit, for 4" gas connection	9495066
Connection fitting kit, for DN 100 ISO-K flange connection	9495166

Protective Accessories	Part Number
Pump thermal protection switch (to be ordered together with the pump)	9495076
Oil separator control pressure switch (to be ordered together with the pump)	9495077
MS-631 oil level protection switch (to be ordered together with the pump)	9495079

Spare Parts	Part Number
MS-631 minor spare part kit	9495087
MS-631 major spare part kit	9495088
Oil filter (type B)	9495090
MS-631 inlet air filter polyester cartridge	9495089
MS-631 exhaust coalescent filter kit	SR03706207

PUMP MODELS

▶ Agilent MS-631 FL (Frameless)



The Agilent MS-631 Frameless (FL) is a high capacity, single stage, oil lubricated rotary vane pump, that can be directly coupled to an Agilent Roots Pump (up to RP-3001 size) without the need of a frame.

The Roots Pump can be mounted directly on the MS-631 FL,

through an appropriate flange that can sustain the weight of the Roots Pump. The Roots Pump can be ordered separately. Please contact Agilent for technical specifications and ordering information.

The two pumps are shipped separately.

Applications

The rugged design, high performance and reliability, and compact size make the MS-631 FL ideal for demanding industrial applications such as thin film coatings, vacuum metallurgy, helium leak detection, and electron beam welding.

Key pump features

- Minimum footprint
- Easy to service
- Oil recirculation system
- Anti-suckback valve prevents system contamination
- Floating oil recovery valve
- Oil-level sight-glass allows quick visual check of pump status
- Carbon composite vanes extend pump life
- Air cooled

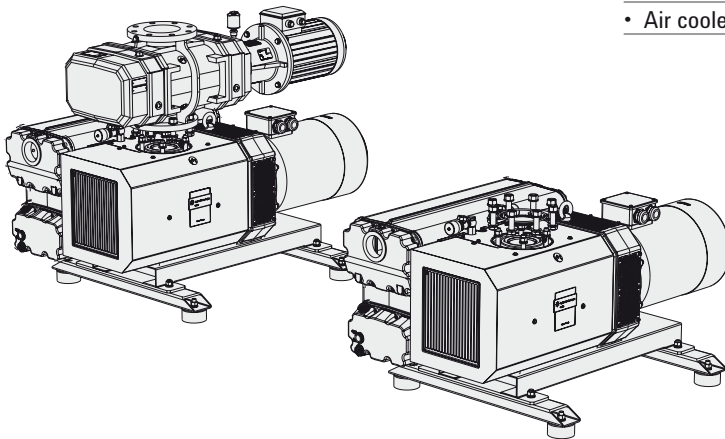

HIGH CAPACITY MS-RPS SERIES

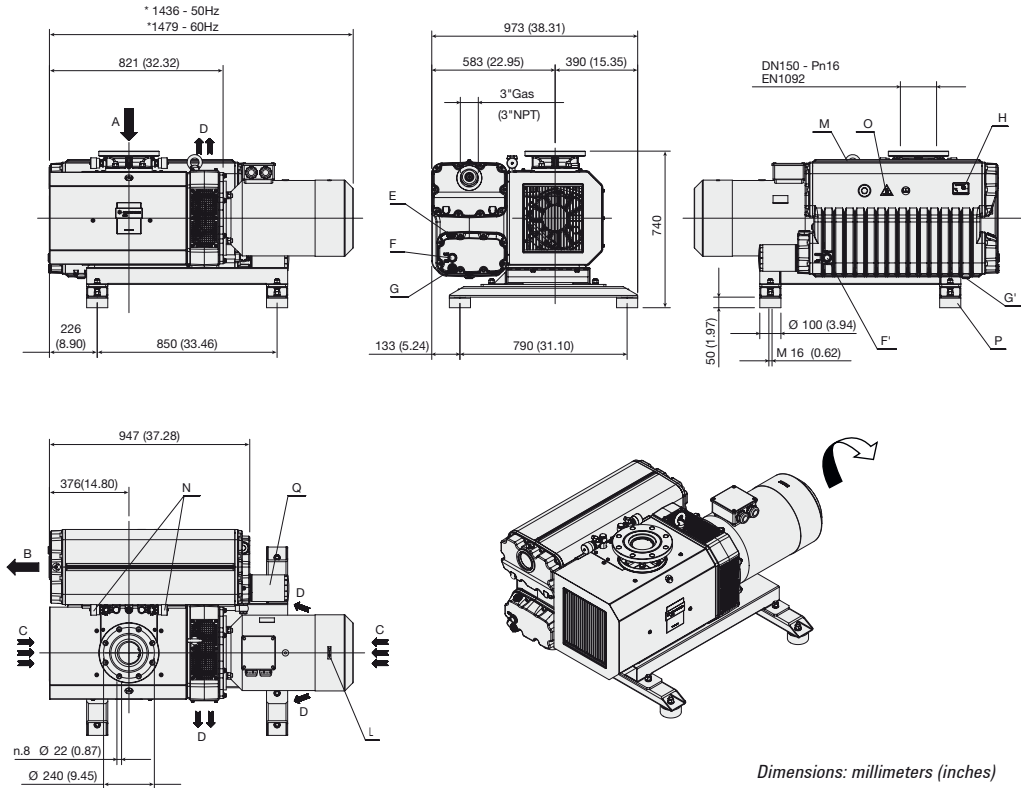

Technical Specifications

MS631FL can be directly coupled with RP-1401, RP-2001 and RP-3001.

Nominal speed*	660 m ³ (at 50 Hz) 790 m ³ (at 60 Hz)
Ultimate partial pressure (with gas ballast valve closed)*	≤ 8 x 10 ⁻² mbar (≤ 8 x 10 ⁻² Torr)
Ultimate total pressure (with gas ballast valve open)*	≤ 0.5 mbar (≤ 0.37 Torr)
Motor power/rotational speed** (3ph)	15 (1000 min-1) kW (rpm) at 50 Hz 18.5 (1200 min-1) kW (rpm) at 60 Hz
Electrical motor characteristics	IM B5 Δ400/Y690 V at 50 Hz, Δ460 V at 60 Hz IM B5 Δ220/Y380 V at 60 Hz IM B5 YY230/Y460 V at 60 Hz
Noise pressure level (without gas ballast valve)***	71 dB(A) at 50 Hz 73 dB(A) at 60 Hz
Water vapor tolerance	60 Hz / 50 Hz: 40/30 mbar (30/23 Torr)
Water vapor capacity	60 Hz / 50 Hz: 30/20 kg/h (33.1/22.0 qt/hr)
Oil capacity	min 19 l max 25 l nominal 22 l
Weight	
with 15.0 kW motor	591 kg (1301.79 lbs)
with 18.5 kW motor	643 kg (1416.33 lbs)
without motor	419 kg (922.93 lbs)
Operating temperature range	12 – 40 °C

* According to PNEURO P standard 6602

** Valid for temperatures up to 40 °C and altitudes lower than 1000 m

*** According to UNI EN ISO 2151 standard

PUMP MODELS

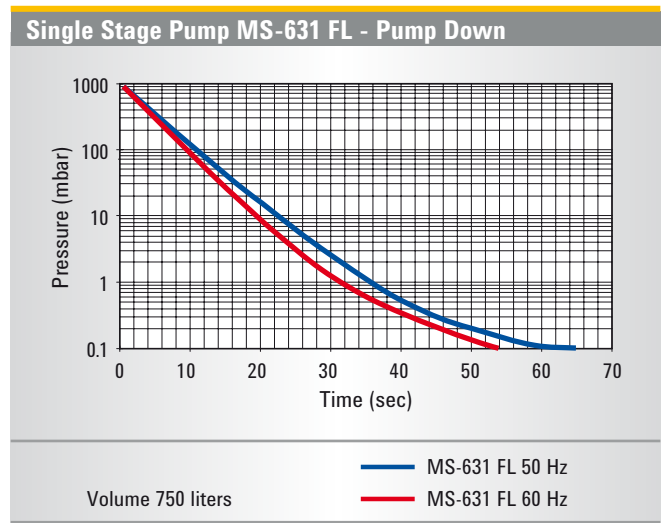
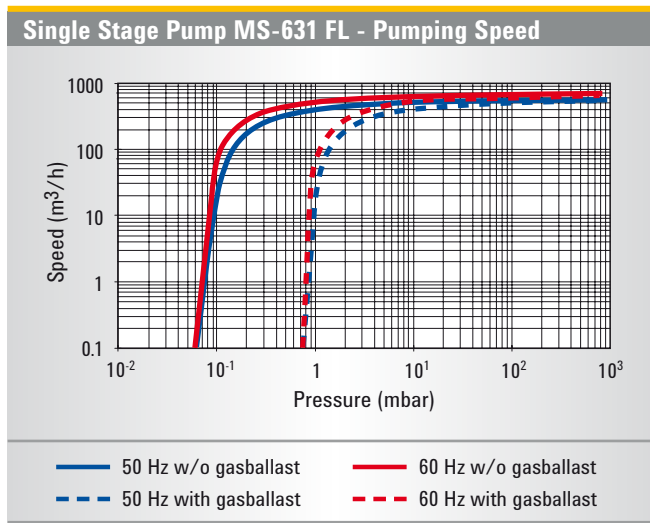

Ordering Information

High Capacity Rotary Vane Pumps *	Part Number
MS-631FL 15.0 kW, Δ400/Y690 V, 50 Hz; IE2; DN150 DIN2533	X3753-64000
MS-631FL 18.5 kW, Δ400/Y690 V, 50 Hz - Δ460 V, 60 Hz; DN150 DIN2533	X3753-64002
MS-631FL 18.5 kW, Δ220/Y380 V, 60 Hz; IE2; DN150 DIN2533	X3753-64006
MS-631FL 18.5 kW, YY230/Y460 V, 60 Hz; IE2; DN150 DIN2533	X3753-64004
Full Optional **	Part Number
MS-631FL 15.0 kW, Δ400/Y690 V, 50 Hz; IE2; DN150 DIN2533	X3753-64091
MS-631FL 18.5 kW, Δ400/Y690 V, 50 Hz - Δ460 V, 60 Hz; DN150 DIN2533	X3753-64092
MS-631FL 18.5 kW, Δ220/Y380 V, 60 Hz; IE2; DN150 DIN2533	X3753-64094
MS-631FL 18.5 kW, YY230/Y460 V, 60 Hz; IE2; DN150 DIN2533	X3753-64093
Oil and Spare Parts	Part Number
MS-01 oil 22 lt	X3760-64003
MS-631 minor spare part kit	9495087
MS-631 major spare part kit	9495088
Oil filter (Type B)	9495090
Frameless upgrade kit for standard MS-631	X3753-64089

* Oil charge not included

** Full optional version include:

- Pump thermal protection switch
- Exhaust filter control pressure switch
- Oil level protection switch

HIGH CAPACITY MS-RPS SERIES

RPS-1401 / MS-631 FL System

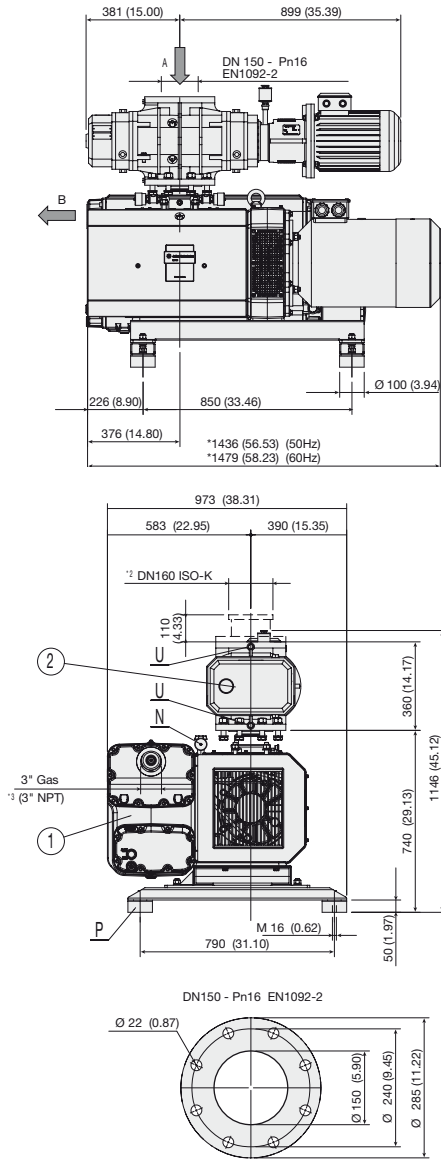

Dimensions: millimeters (inches)

RPS-1401 / MS-631 FL - Pumping Speed

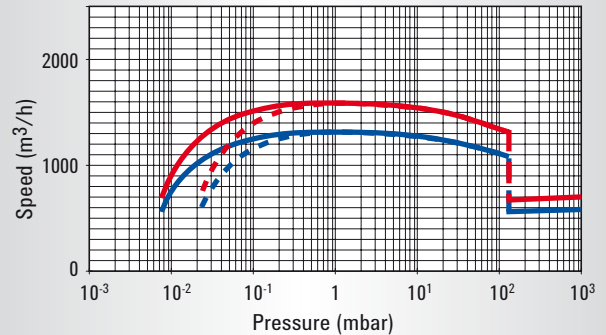

— 50 Hz w/o gasballast — 60 Hz w/o gasballast
 - - 50 Hz with gasballast - - 60 Hz with gasballast

High Capacity
MS-RPS Pumps

Technical Specifications

Nominal speed* 1430 m³/h (at 50 Hz)
1720 m³/h (at 60 Hz)

Ultimate partial pressure
(with gas ballast valve closed)*
(absolute) ≤ 0.007 mbar (≤ 0.005 Torr)

Ultimate total pressure
(with gas ballast valve open)*
(absolute) ≤ 0.02 mbar (≤ 0.015 Torr)

Start up pressure RP1401
(absolute) ≤ 130 mbar (≤ 97 Torr)

Fitted motor power (MS + RP)** 15 + 5.5 (400 V) kW at 50 Hz
18.5 + 5.5 (460 V) kW at 60 Hz

Noise pressure level*** 75 dB(A) at 50 Hz
76.5 dB(A) at 60 Hz

Oil capacity (MS + RP) nominal 22 + 1.5 l

Weight
with 3 ph 50 Hz motor 868 (1911.94) kg (lb)
with 3 ph 60 Hz motor 937 (2063.92) kg (lb)

* According to PNEURO standard 6602

** Valid for temperatures up to 40 °C and altitudes lower than 1000 m

*** According to UNI EN ISO 2151 standard

PUMP MODELS

► RPS-2001 / MS-631 FL System

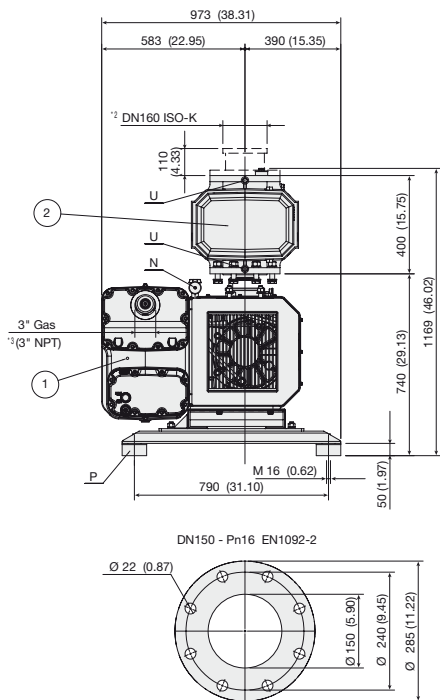
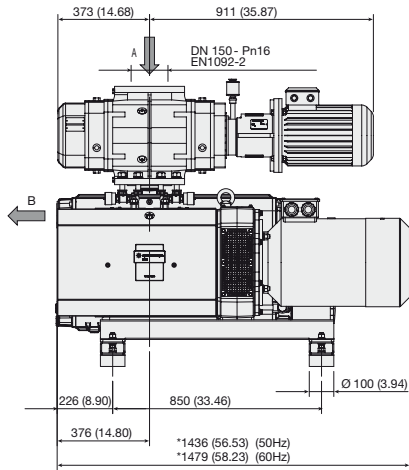

Dimensions: millimeters (inches)

RPS-2001 / MS-631 FL - Pumping Speed

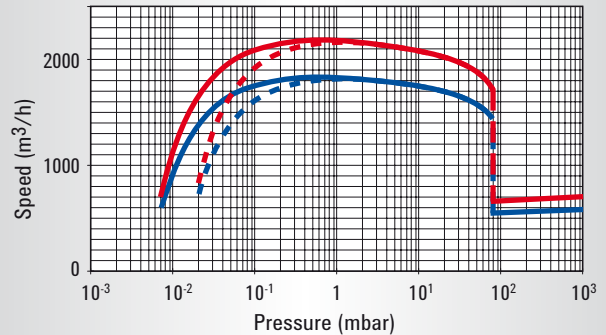

— 50 Hz w/o gasballast — 60 Hz w/o gasballast
 - - - 50 Hz with gasballast - - - 60 Hz with gasballast

Technical Specifications

Nominal speed*	2045 m ³ /h (at 50 Hz) 2444 m ³ /h (at 60 Hz)
Ultimate total pressure (with gas ballast valve closed)* (absolute)	≤ 7 x 10 ⁻³ mbar (≤ 7 x 10 ⁻¹ Pascal)
Ultimate total pressure (with gas ballast valve open)* (absolute)	≤ 2 x 10 ⁻² mbar (≤ 2 Pascal)
Start up pressure RP2001 (absolute)	≤ 80 mbar (≤ 60 Torr)
Fitted motor power** (MS + RP)	15 + 7.5 (400 V) kW at 50 Hz 18.5 + 7.5 (460 V) kW at 60 Hz
Noise pressure level***	77 dB(A) at 50 Hz 78 dB(A) at 60 Hz
Oil capacity (MS + RP) nominal	22 + 2.5 l
Weight	
with 3 ph 50 Hz motor	920 (2026.48) kg (lb)
with 3 ph 60 Hz motor	986 (2171.85) kg (lb)

* According to PNEUROP standard 6602

** Valid for temperatures up to 40 °C and altitudes lower than 1000 m

*** According to UNI EN ISO 2151 standard

HIGH CAPACITY MS-RPS SERIES

RPS-3001 / MS-631 FL System

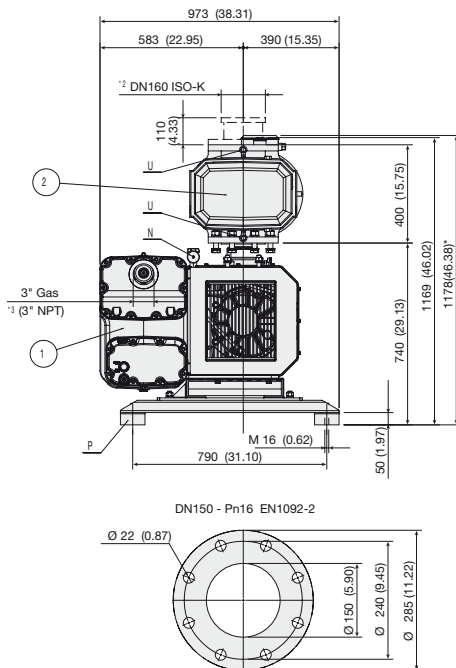
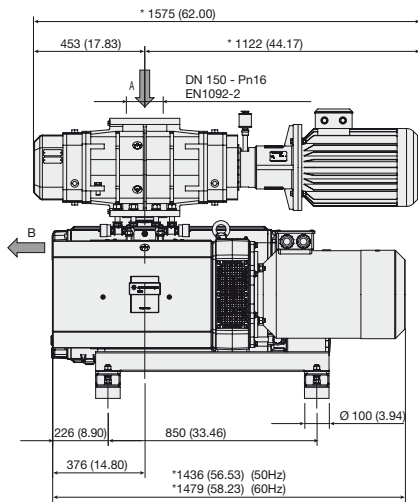

Dimensions: millimeters (inches)

RPS-3001 / MS-631 FL - Pumping Speed

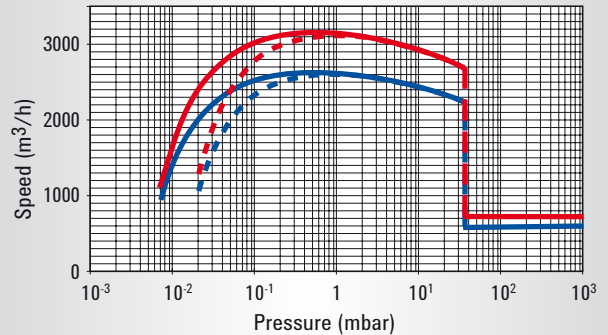

— 50 Hz w/o gasballast — 60 Hz w/o gasballast
 - - - 50 Hz with gasballast - - - 60 Hz with gasballast

High Capacity
MS-RPS Pumps

Technical Specifications

Nominal speed*	2890 m ³ /h (at 50 Hz) 3465 m ³ /h (at 60 Hz)
Ultimate total pressure (with gas ballast valve closed)* (absolute)	≤ 7 x 10 ⁻³ mbar (≤ 7 x 10 ⁻¹ Pascal)
Ultimate total pressure (with gas ballast valve open)* (absolute)	≤ 2 x 10 ⁻² mbar (≤ 2 Pascal)
Start up pressure RP3001 (absolute)	< 36 mbar (< 27 Torr)
Fitted motor power** (MS + RP)	15 + 11 (400 V) kW at 50 Hz 18.5 + 11 (460 V) kW at 60 Hz
Noise pressure level***	77.5 dB(A) at 50 Hz 78.5 dB(A) at 60 Hz
Oil capacity (MS + RP) nominal	22 + 2.5 l
Weight	
with 3 ph 50 Hz motor	1052 (2317.23) kg (lb)
with 3 ph 60 Hz motor	1140 (2511.07) kg (lb)

* According to PNEUROP standard 6602

** Valid for temperatures up to 40 °C and altitudes lower than 1000 m

*** According to UNI EN ISO 2151 standard

RPS PUMPING SYSTEMS MODELS

▶ Agilent RPS-Series Roots Pumping Systems

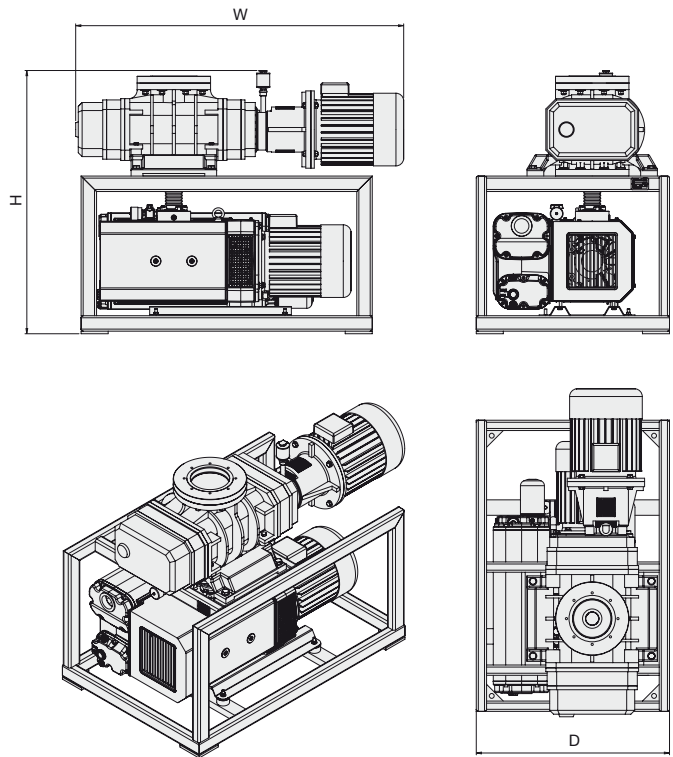
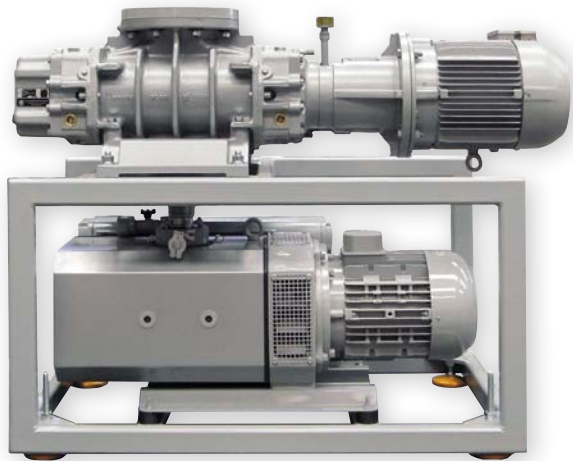

Roots Pumping Systems (RPS) consist of one MS Rotary Vane Pump and one RP Roots Pump, assembled on a dedicated frame, and connected in series with a flexible hose. This assembly is shipped with the pumps mounted on the frame and leak checked. Both pumps are equipped with motor.

Photo and Outline Drawing: RPS-1401/301

▶ Agilent RP-Series Roots Pumps

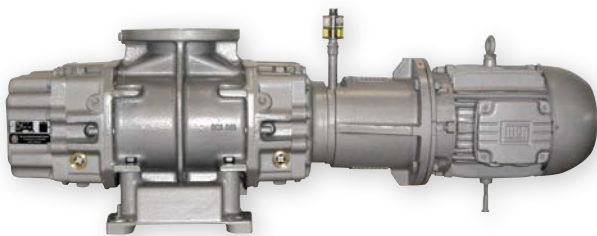

State-of-the-art, high performance Agilent Roots Pumps are ideal for use in demanding industrial applications:

- Highest compression ratio
- Agilent Roots Pumps can withstand high mechanical loads reducing pumpdown cycles
- Lowest base pressure: 5×10^{-3} mbar (4×10^{-3} Torr)

HIGH CAPACITY MS-RPS SERIES

High Capacity MS-RPS Pumps

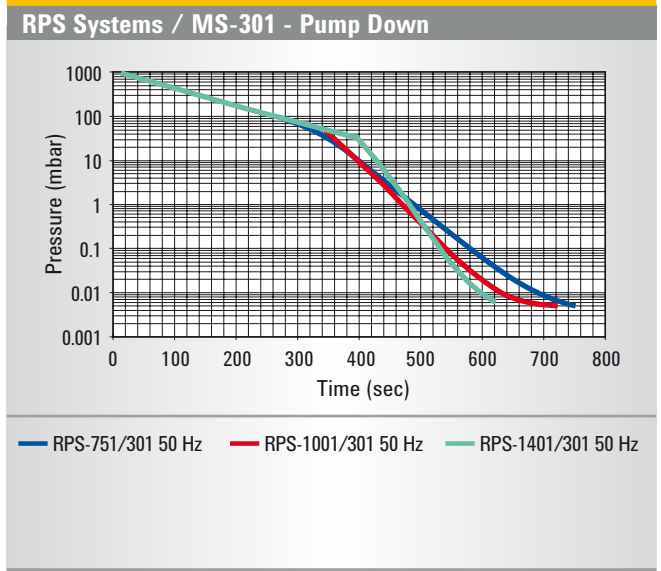
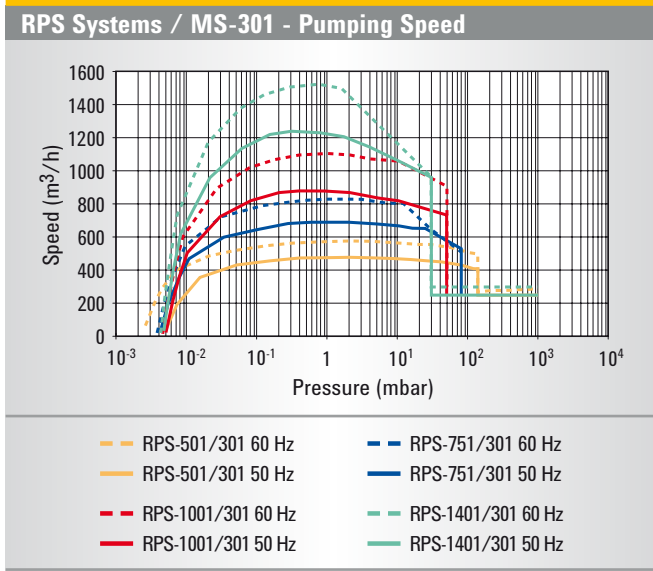

Technical Specifications

		RPS-501/301	RPS-751/301
Nominal pumping speed	60 Hz	600 m ³ /h (350 cfm)	900 m ³ /h (530 cfm)
	50 Hz	500 m ³ /h (300 cfm)	750 m ³ /h (440 cfm)
Ultimate total pressure (gas ballast closed)		≤ 7 × 10 ⁻³ mbar (≤ 5 × 10 ⁻³ Torr)	≤ 5 × 10 ⁻³ mbar (≤ 4 × 10 ⁻³ Torr)
Roots pump start up pressure		≤ 200 mbar (≤ 152 Torr)	≤ 80 mbar (≤ 60 Torr)
Power	60 Hz	2.6 + 7.5 kW (3.5 + 10.0 HP)	3.6 + 7.5 kW (4.8 + 10.0 HP)
	50 Hz	2.2 + 5.5 kW (2.9 + 7.3 HP)	3.0 + 5.5 kW (4.0 + 7.3 HP)
Power supply voltage		Δ230/Y400 V at 50 Hz Δ460 V at 60 Hz YY230/Y460 V at 60 Hz Δ220/Y380 V at 60 Hz	Δ230/Y400 V at 50 Hz Δ460 V at 60 Hz YY230/Y460 V at 60 Hz Δ220/Y380 V at 60 Hz
Noise level*		74 / 76 dB(A)	74 / 76 dB(A)
Oil charge		1.1 + 7.0 liter (1.16 + 7.4 qt)	1.5 + 7.0 liter (1.6 + 7.4 qt)
Working ambient temperature range		+12 +40 °C (+54 +105 F)	+12 +40 °C (+54 +105 F)
Storage temperature		-15 +50 °C (+5 +122 F)	-20 +70 °C (-4 +158 F)
Dimensions D x W x H		750 x 1048 x 1086 / 750 x 1088 x 1086 mm (29.5 x 41.3 x 42.8 / 29.5 x 42.8 x 42.8 in.)	750 x 1130 x 1175 mm (29.5 x 44.5 x 46.3 in.)
Total weight	60 Hz	445 kg (981 lbs)	470 kg (1040 lbs)
	50 Hz	430 kg (948 lbs)	450 kg (1000 lbs)
		RPS-1001/301	RPS-1401/301
Nominal pumping speed	60 Hz	1200 m ³ /h (710 cfm)	1700 m ³ /h (1000 cfm)
	50 Hz	1000 m ³ /h (590 cfm)	1430 m ³ /h (840 cfm)
Ultimate total pressure (gas ballast closed)		≤ 5 × 10 ⁻³ mbar (≤ 4 × 10 ⁻³ Torr)	≤ 5 × 10 ⁻³ mbar (≤ 4 × 10 ⁻³ Torr)
Roots pump start up pressure		≤ 50 mbar (≤ 38 Torr)	≤ 30 mbar (≤ 23 Torr)
Power	60 Hz	4.8 + 7.5 kW (6.4 + 10.0 HP)	6.3 + 7.5 kW (8.4 + 10.0 HP)
	50 Hz	4.0 + 5.5 kW (5.3 + 7.3 HP)	5.5 + 5.5 kW (7.3 + 7.3 HP)
Power supply voltage		Δ230/Y400 V at 50 Hz Δ400/Y690 V at 50 Hz Δ460 V at 60 Hz YY230/Y460 V at 60 Hz Δ220/Y380 V at 60 Hz	Δ230/Y400 V at 50 Hz Δ400/Y690 V at 50 Hz Δ460 V at 60 Hz YY230/Y460 V at 60 Hz Δ220/Y380 V at 60 Hz
Noise level*		74 / 76 dB(A)	74 / 76 dB(A)
Oil charge		1.5 + 7.0 liter (1.6 + 7.4 qt)	1.5 + 7.0 liter (1.6 + 7.4 qt)
Working ambient temperature range		+12 +40 °C (+54 +105 F)	+12 +40 °C (+54 +105 F)
Storage temperature		-20 +70 °C (-4 +158 F)	-20 +70 °C (-4 +158 F)
Dimensions D x W x H		750 x 1153 x 1195 mm (29.5 x 45.4 x 47 in.)	750 x 1289 x 1195 mm (29.5 x 50.7 x 47 in.)
Total weight	60 Hz	530 kg (1170 lbs)	590 kg (1300 lbs)
	50 Hz	510 kg (1130 lbs)	570 kg (1260 lbs)

* Measured according to EN ISO 2151 (50/60 Hz)

RPS PUMPING SYSTEMS MODELS

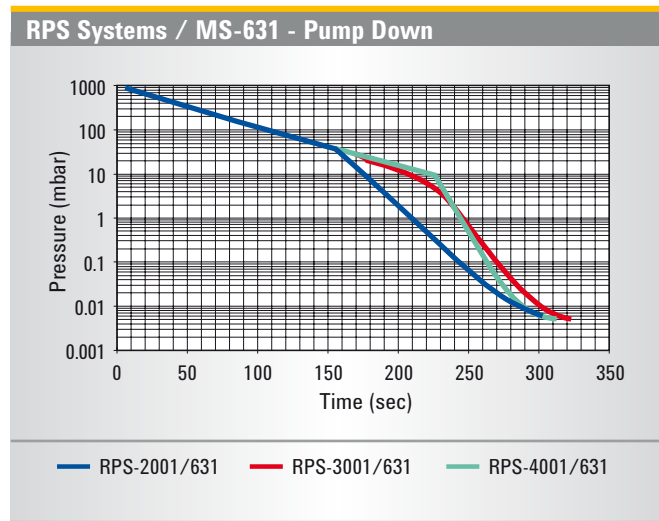
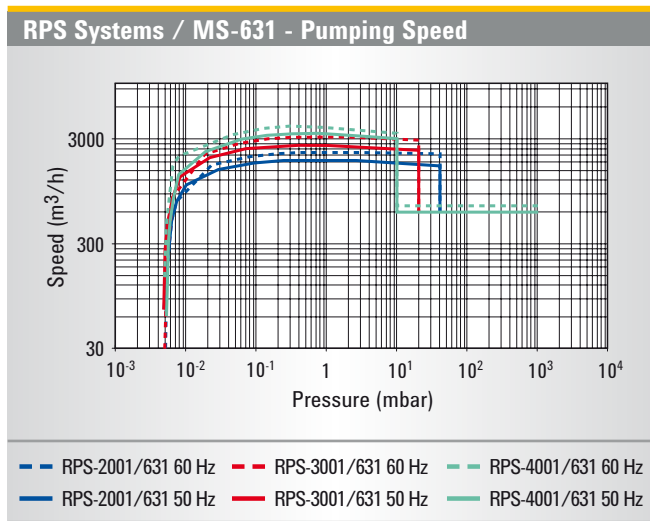

Technical Specifications

		RPS-2001/631		RPS-3001/631	
Nominal pumping speed	60 Hz	2400 m ³ /h (1415 cfm)		3450 m ³ /h (2030 cfm)	
	50 Hz	2000 m ³ /h (1180 cfm)		2900 m ³ /h (1710 cfm)	
Ultimate total pressure (gas ballast closed)		≤ 5 x 10 ⁻³ mbar (≤ 4 x 10 ⁻³ Torr)		≤ 5 x 10 ⁻³ mbar (≤ 4 x 10 ⁻³ Torr)	
Roots pump start up pressure		≤ 55 mbar (≤ 42 Torr)		≤ 30 mbar (≤ 23 Torr)	
Power	60 Hz	8.8 + 18.5 kW (11.8 + 24.8 HP)		12.5 + 18.5 kW (16.7 + 24.8 HP)	
	50 Hz	7.5 + 15.0 kW (10.0 + 20.1 HP)		11.0 + 15.0 kW (14.7 + 20.1 HP)	
Power supply voltage		Δ400/Y690 V at 50 Hz Δ460 V at 60 Hz YY230/Y460 V at 60 Hz Δ220/Y380 V at 60 Hz		Δ400/Y690 V at 50 Hz Δ460 V at 60 Hz YY230/Y460 V at 60 Hz Δ220/Y380 V at 60 Hz	
Noise level*		78 / 80 dB(A)		78 / 80 dB(A)	
Oil charge		2.5 + 22.0 liter (2.6 + 23.2 qt)		2.5 + 22.0 liter (2.6 + 23.2 qt)	
Working ambient temperature range		+12 +40 °C (+54 +105 F)		+12 +40 °C (+54 +105 F)	
Storage temperature		-20 +70 °C (-4 +158 F)		-20 +70 °C (-4 +158 F)	
Dimensions D x W x H		1050 x 1575 [1605 version 60 Hz] x 1516 mm (41.3 x 62 [63.2 version 60 Hz] x 59.7 in.)		1050 x 1615 x 1516 mm (41.3 x 63.6 x 59.7 in.)	
Total weight	60 Hz	1115 kg (2460 lbs)		1255 kg (2770 lbs)	
	50 Hz	1085 kg (2400 lbs)		1225 kg (2700 lbs)	
		RPS-4001/631			
Nominal pumping speed	60 Hz	4700 m ³ /h (2770 cfm)			
	50 Hz	3900 m ³ /h (2300 cfm)			
Ultimate total pressure (gas ballast closed)		≤ 5 x 10 ⁻³ mbar (≤ 4 x 10 ⁻³ Torr)			
Roots pump start up pressure		≤ 16 mbar (≤ 12 Torr)			
Power	60 Hz	12.5 + 18.5 kW (16.7 + 24.8 HP)			
	50 Hz	11.0 + 15.0 kW (14.7 + 20.1 HP)			
Power supply voltage		Δ400/Y690 V at 50 Hz Δ460 V at 60 Hz YY230/Y460 V at 60 Hz Δ220/Y380 V at 60 Hz			
Noise level*		79 / 81 dB(A)			
Oil charge		7.0 + 22.0 liter (7.4 + 23.2 qt)			
Working ambient temperature range		+12 +40 °C (+54 +105 F)			
Storage temperature		-20 +70 °C (-4 +158 F)			
Dimensions D x W x H		1050 x 1636 x 1576 mm (41.3 x 64.4 x 62 in.)			
Total weight	60 Hz	1380 kg (3050 lbs)			
	50 Hz	1340 kg (2960 lbs)			

* measured according to EN ISO 2151 (50/60 Hz)

HIGH CAPACITY MS-RPS SERIES

Ordering Information

Roots Pumping Systems including: Roots Pump, RV Pump, Frame, Flexible Hose, Roots Pump Oil, Assembly, Testing and Packaging. MS PUMP OIL CHARGE NOT INCLUDED.	Part Number
RPS-501/301, 230/400V, 50Hz	X3755-64000
RPS-501/301, 230/460V, 60Hz (US version)	X3755-64008
RPS-501/301, 220/380V, 60Hz	X3755-64012
RPS-751/301, 230/400V, 50Hz	X3755-64001
RPS-751/301, 230/460V, 60Hz (US version)	X3755-64009
RPS-751/301, 220/380V, 60Hz	X3755-64013
RPS-1001/301, 230/400V, 50Hz	X3755-64002
RPS-1001/301, 400/690V, 50Hz	X3755-64004
RPS-1001/301, 400/690V, 50Hz - 460V,60Hz	X3755-64006
RPS-1001/301, 230/460V, 60Hz (US version)	X3755-64010
RPS-1001/301, 220/380V, 60Hz	X3755-64014
RPS-1401/301, 230/400V, 50Hz	X3755-64003
RPS-1401/301, 400/690V, 50Hz	X3755-64005
RPS-1401/301, 400/690V, 50Hz - 460V,60Hz	X3755-64007
RPS-1401/301, 230/460V, 60Hz (US version)	X3755-64011
RPS-1401/301, 220/380V, 60Hz	X3755-64015
RPS-2001/631, 400/690V, 50Hz	X3756-64002
RPS-2001/631, 400/690V, 50Hz - 460V,60Hz	X3756-64007
RPS-2001/631, 230/460V, 60Hz (US version)	X3756-64012
RPS-2001/631, 220/380V, 60Hz	X3756-64017
RPS-3001/631, 400/690V, 50Hz	X3756-64003
RPS-3001/631, 400/690V, 50Hz - 460V,60Hz	X3756-64008
RPS-3001/631, 230/460V, 60Hz (US version)	X3756-64013
RPS-3001/631, 220/380V, 60Hz	X3756-64018
RPS-4001/631, 400/690V, 50Hz	X3756-64004
RPS-4001/631, 400/690V, 50Hz - 460V,60Hz	X3756-64009
RPS-4001/631, 230/460V, 60Hz (US version)	X3756-64014
RPS-4001/631, 220/380V, 60Hz	X3756-64019

* Other combinations available on request. Please contact Agilent for details

RPS PUMPING SYSTEMS MODELS

Ordering Information

Roots Pumps / MS PUMP OIL CHARGE NOT INCLUDED	Part Number
RP-251, 1.1kW, 230/400V, 50Hz-460V, 60Hz	X3757-64251
RP-251, 1.1kW, 230/460V, 60Hz	X3757-64252
RP-251, 1.1kW, 220/380V, 60Hz	X3757-64253
RP-501, 2.2kW 230/400V, 50Hz - 460V, 60Hz	X3757-64501
RP-501, 2.2kW, 230/460V, 60Hz	X3757-64502
RP-501, 2.2kW, 220/380V, 60Hz	X3757-64503
RP-751, 3kW, 230/400V, 50Hz - 460V, 60Hz	X3758-64751
RP-751, 3kW, 230/460V, 60Hz	X3758-64752
RP-751, 3kW, 220/380V, 60Hz	X3758-64753
RP-1001, 4kW, 230/400V, 50Hz - 460V, 60Hz	X3758-64001
RP-1001, 4kW, 400/690V, 50Hz - 460V, 60Hz	X3758-64002
RP-1001, 4kW, 230/460V, 60Hz	X3758-64003
RP-1001, 4kW, 230/380V, 60Hz	X3758-64004
RP-1401, 4kW, 220/380V, 60Hz - To be used with VFD	X3758-64007
RP-1401, 4kW, 230/400V, 50Hz - 460V, 60Hz - To be used with VFD	X3758-64009
RP-1401, 4kW, 400/690V, 50Hz - 460V, 60Hz - To be used with VFD	X3758-64010
RP-1401, 5.5kW 230/400V, 50Hz-460V, 60Hz	X3758-64401
RP-1401, 5.5kW 400/690V, 50Hz-460V, 60Hz	X3758-64402
RP-1401, 5.5kW, 230/460V, 60Hz	X3758-64403
RP-1401, 5.5kW, 230/380V, 60Hz	X3758-64404
RP-2001, 5.5kW, 220/380V, 60Hz - To be used with VFD	X3759-64001
RP-2001, 5.5kW, 230/460V, 60Hz - To be used with VFD	X3759-64002
RP-2001, 5.5kW, 400/690V, 50Hz-460V, 60Hz - To be used with VFD	X3759-64003
RP-2001, 7.5kW 400/690V, 50Hz-460V, 60Hz	X3759-64201
RP-2001, 7.5kW, 230/460V, 60Hz	X3759-64202
RP-2001, 7.5kW, 230/380V, 60Hz	X3759-64203
RP-3001, 11kW 400/690V, 50Hz-460V, 60Hz	X3759-64301
RP-3001, 11kW, 230/460V, 60Hz	X3759-64302
RP-3001, 11kW, 230/380V, 60Hz	X3759-64303
RP-4001, 11kW 400/690V, 50Hz-460V, 60Hz	X3759-64401
RP-4001, 11kW, 230/460V, 60Hz	X3759-64402
RP-4001, 11kW, 230/380V, 60Hz	X3759-64403
Inverter 4kW, three-phase, 380-480V, IP20, plus software suitable for RP-1401 paired with MS-631	X3761-64012
Inverter 4kW, three-phase, 380-480V, IP66, plus software suitable for RP-1401 paired with MS-631	X3761-64013
Inverter 5.5kW, three-phase, 380-480V, IP20, plus software suitable for RP-2001 paired with MS-631	X3761-64014
Inverter 5.5kW, three-phase, 380-480V, IP66, plus software suitable for RP-2001 paired with MS-631	X3761-64015
Support Mounting Kit, for 4kW inverter	X3761-64016
Support Mounting Kit, for 5.5kW inverter	X3761-64017

HIGH CAPACITY MS-RPS SERIES

Ordering Information

Spare Part Kits & Accessories	Part Number
RP-1001 Minor Spare Part Kit	9497020
RP-751 Minor Spare Part Kit	9497021
RP-1401 Minor Spare Part Kit	9497022
RP-2001 Minor Spare Part Kit	9497023
RP-3001 Minor Spare Part Kit	9497024
RP-4001 Minor Spare Part Kit	9497025
RP-1001 Major Spare Part Kit	9497026
RP-751 Major Spare Part Kit	9497027
RP-1401 Major Spare Part Kit	9497028
RP-2001 Major Spare Part Kit	9497029
RP-3001 Major Spare Part Kit	9497030
RP-4001 Major Spare Part Kit	9497031
DN80Pn16 to DN63ISO-K Adapter Flange Kit	X3761-64000
DN100Pn16 to DN63ISO-K Adapter Flange Kit	X3761-64001
DN100Pn16 to DN100ISO-K Adapter Flange Kit	X3761-64002
DN150Pn16 to DN100ISO-K Adapter Flange Kit	X3761-64003
DN150Pn16 to DN160ISO-K Adapter Flange Kit	X3761-64004
DN63 ISO-K Inlet Mesh Kit	X3761-64005
DN100 ISO-K Inlet Mesh Kit	X3761-64006
DN160 ISO-K Inlet Mesh Kit	X3761-64007

По вопросам продаж и поддержки обращайтесь:

Алматы (7273)495-231	Казань (843)206-01-48	Новокузнецк (3843)20-46-81	Смоленск (4812)29-41-54
Архангельск (8182)63-90-72	Калининград (4012)72-03-81	Новосибирск (383)227-86-73	Сочи (862)225-72-31
Астрахань (8512)99-46-04	Калуга (4842)92-23-67	Омск (3812)21-46-40	Ставрополь (8652)20-65-13
Барнаул (3852)73-04-60	Кемерово (3842)65-04-62	Орел (4862)44-53-42	Сургут (3462)77-98-35
Белгород (4722)40-23-64	Киров (8332)68-02-04	Оренбург (3532)37-68-04	Тверь (4822)63-31-35
Брянск (4832)59-03-52	Краснодар (861)203-40-90	Пенза (8412)22-31-16	Томск (3822)98-41-53
Владивосток (423)249-28-31	Красноярск (391)204-63-61	Пермь (342)205-81-47	Тула (4872)74-02-29
Волгоград (844)278-03-48	Курск (4712)77-13-04	Ростов-на-Дону (863)308-18-15	Тюмень (3452)66-21-18
Вологда (8172)26-41-59	Липецк (4742)52-20-81	Рязань (4912)46-61-64	Ульяновск (8422)24-23-59
Воронеж (473)204-51-73	Магнитогорск (3519)55-03-13	Самара (846)206-03-16	Уфа (347)229-48-12
Екатеринбург (343)384-55-89	Москва (495)268-04-70	Санкт-Петербург (812)309-46-40	Хабаровск (4212)92-98-04
Иваново (4932)77-34-06	Мурманск (8152)59-64-93	Саратов (845)249-38-78	Челябинск (351)202-03-61
Ижевск (3412)26-03-58	Набережные Челны (8552)20-53-41	Севастополь (8692)22-31-93	Череповец (8202)49-02-64
Иркутск (395)279-98-46	Нижний Новгород (831)429-08-12	Симферополь (3652)67-13-56	Ярославль (4852)69-52-93
Россия (495)268-04-70	Киргизия (996)312-96-26-47	Казахстан (7172)727-132	