

# Технические характеристики

## По вопросам продаж и поддержки обращайтесь:

Алматы (7273)495-231	Казань (843)206-01-48	Новокузнецк (3843)20-46-81	Смоленск (4812)29-41-54
Архангельск (8182)63-90-72	Калининград (4012)72-03-81	Новосибирск (383)227-86-73	Сочи (862)225-72-31
Астрахань (8512)99-46-04	Калуга (4842)92-23-67	Омск (3812)21-46-40	Ставрополь (8652)20-65-13
Барнаул (3852)73-04-60	Кемерово (3842)65-04-62	Орел (4862)44-53-42	Сургут (3462)77-98-35
Белгород (4722)40-23-64	Киров (8332)68-02-04	Оренбург (3532)37-68-04	Тверь (4822)63-31-35
Брянск (4832)59-03-52	Краснодар (861)203-40-90	Пенза (8412)22-31-16	Томск (3822)98-41-53
Владивосток (423)249-28-31	Красноярск (391)204-63-61	Пермь (342)205-81-47	Тула (4872)74-02-29
Волгоград (844)278-03-48	Курск (4712)77-13-04	Ростов-на-Дону (863)308-18-15	Тюмень (3452)66-21-18
Вологда (8172)26-41-59	Липецк (4742)52-20-81	Рязань (4912)46-61-64	Ульяновск (8422)24-23-59
Воронеж (473)204-51-73	Магнитогорск (3519)55-03-13	Самара (846)206-03-16	Уфа (347)229-48-12
Екатеринбург (343)384-55-89	Москва (495)268-04-70	Санкт-Петербург (812)309-46-40	Хабаровск (4212)92-98-04
Иваново (4932)77-34-06	Мурманск (8152)59-64-93	Саратов (845)249-38-78	Челябинск (351)202-03-61
Ижевск (3412)26-03-58	Набережные Челны (8552)20-53-41	Севастополь (8692)22-31-93	Череповец (8202)49-02-64
Иркутск (395)279-98-46	Нижний Новгород (831)429-08-12	Симферополь (3652)67-13-56	Ярославль (4852)69-52-93
Россия (495)268-04-70	Киргизия (996)312-96-26-47	Казахстан (7172)727-132	

# FEATURES AND BENEFITS

## Vacuum Measurement for Science and Industry

Agilent vacuum gauges and controllers are reliable, accurate, and cost-effective tools for measuring and controlling vacuum pressure in a wide range of applications.

- Agilent features pressure measurement technology designed for challenging industrial environments: simplicity, rugged design, plus ease of service to insure maximum productivity and uptime in your vacuum system or vacuum process.
- With over 50 years experience in science research, our superior accuracy and stability meets the most demanding scientific requirements.



### Rough Gauge Controllers

Reliable, cost-effective solutions for pressure measurement from  $1 \times 10^{-3}$  Torr to 760 Torr, these controllers come with the Agilent TC tube and cable and are pre-calibrated.

- Ready to install and operate
- Two easily configured set points to facilitate critical operations
- Large, bright LED display is easily read across a room or in dimly lit locations



### Active Gauge Controllers

These single channel controllers operate the FRG-, PVG-, PCG-, and CDG-series of Active Gauges. Both provide user selectable measurement units and adjustable set point control.

- Easy to set up
- Automatically identify the gauge type when connected
- Adjustable set point control enable critical process steps or operations

### User Friendly Interface

UNITS	TORR
SETUP LOCKOUT	ON
AUTO FILAMENT ADVANCE	OFF
ATMOSPHERE VALUE	760
SERIAL MODE	RS232
SERIAL BAUD RATE	19200
RS485 ADDRESS	00

System Setup

#	SETPT	ON&DELAY	OFF&DELAY	EXIT
1	HFIG1	3E-09 0.0	9E-08 0.0	OFF
2	HFIG2	8E-08 0.1	3E-06 2.0	AUTO
3	IMG1	7E-08 0.0	5E-07 0.0	AUTO
4	IMG2	2E-09 0.5	1E-08 0.1	AUTO
5	CNV1	6E+02 0.0	7E+02 0.0	AUTO
6	CNV2	1E		
7	CNV3	8E		
8	CNV4	1E		

Set Points

TORR	
HFIG1	1.8E-5
IMG2	7.1E-7

Large Font

SENSOR SETUP	
SENSOR ID	HFIG1
USER LABEL	HFIG1
SENSOR MODEL	UHV24
AUTO ON IF GAUGE	CNV1
IS LESS THAN	5E-3
SENSITIVITY	01.0
EMIS CURRENT(MA)	04.0
GAS CORRECTION	1.00

Sensor Setup

# VACUUM MEASUREMENT

## XGS-600 Gauge Controller

### Intelligent Design & Functionality

- Simultaneous operation of all gauges
    - up to 12
  - < 20 millisecond signal-to-set- point response time
  - Displays up to 8 gauges at one time
- Standard features include:
    - 16 gauge set points
    - fully programmable RS-232/485 serial communications
    - E-beam degas for hot filament gauges
    - pressure unit selection: Torr, mbar, Pascal
    - universal voltage compatibility
    - analog output

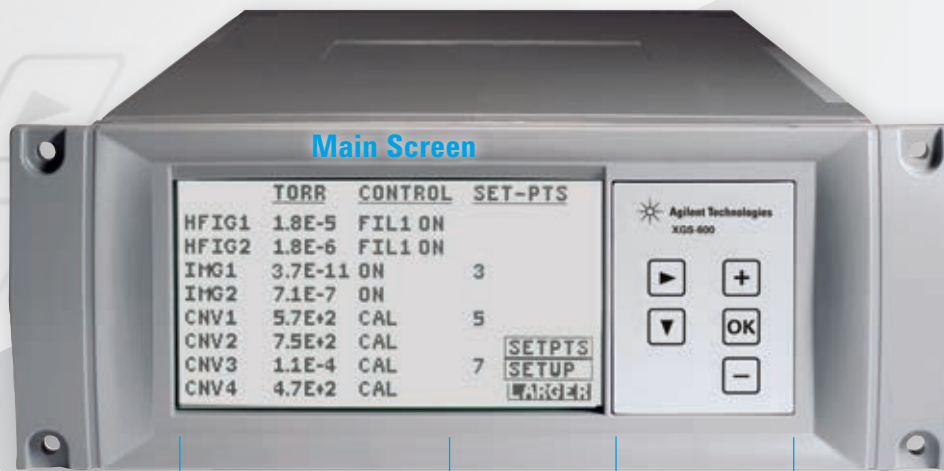

### Intuitive screen functions

- Displays up to 8 gauges on one screen
- Customizable gauge labels

### Easy key pad navigation

### Capacity, Flexibility & Expandability

Only 3 gauge cards operate all Agilent gauges:

- Add a gauge card when needed, simply and quickly
- Save the cost of additional controllers

Simultaneous operation of:

- Up to 4 hot filament gauges plus 4 convection gauges
- Up to 5 inverted magnetron gauges
- Up to 12 convection gauges



# AGILENT GAUGE SELECTION CHART

## ROUGH VACUUM

atm to  $10^{-3}$

### Transducers

Controller Required

**536** ConvecTorr quality accuracy and repeatability  
page 341



**ConvecTorr**  
Best overall accuracy and repeatability. Secure bayonet connector.  
page 340



**531** Most economical rough gauge  
page 341



*convection board*



## HIGH VACUUM

$10^{-3}$  to  $10^{-9}$

**572** Glass; most popular general purpose HV gauge (hot filament). Dual filament.  
page 343



**571** Glass; same as 563 without platinum coating  
page 344



**563** Best general purpose HV gauge (hot filament) for overall performance and reliability.  
page 345



**MBA2-200**  
Small, rugged, wide range  
page 346



**IMG-100** Most durable HV gauge (cold cathode); fastest response  
page 347



*hot filament board*

*cold cathode board*



## ULTRA HIGH VACUUM

$10^{-9}$  to  $10^{-12}$

**UHV-24** Most popular UHV gauge (hot filament)  
**UHV-24p** UHV gauge –highest vacuum reading  
page 349



*hot filament board*



**IMG-300** Most durable, UHV gauge (cold cathode); fastest response  
page 348



*cold cathode board*



# VACUUM MEASUREMENT

## Rough Gauge Packages

RGC-100/RGC-150:  
Pre-calibrated rough gauges and controller packages



XGS-600 analog board



## XGS-600

Multi-gauge Controller



## Active Gauge Controller/Display

AGC-100/AGD-100: Low cost active gauge controllers automatically identify the connected gauge



## Active Gauges

No Controller Required

**PVG-500** Robust, reliable;  
general rough vacuum use  
page 350



**CDG-500** Full scale range  
options; push-button zeroing  
and setpoints  
page 352



**PCG-750** Combo Pirani  
and CDG for accuracy and  
gas-type independence  
page 354



**FRG-700** Combo Pirani  
and IMG – accuracy from  
ATM through HV

**FRG-720/730** Combo  
Pirani and B/A - widest  
vacuum measurement range  
page 356





# APPLICATIONS

## Physics R&D, Accelerators

- **Synchrotron Light Sources and Beam Lines**
- **Particle Accelerator Rings**

Vacuum gauges are widely used in High Energy Physics, Fusion Technology and general UHV research. Synchrotron Light Sources, Particle Accelerator Rings, UHV Laboratory research, and Fusion reactors need extremely accurate, reliable and cost effective HV and UHV gauges. Agilent offers a full range of vacuum transducers that can be equipped with high function controllers to monitor and control HV and UHV environments. If desired, Agilent also offers “Active Gauges” equipped with on-board controllers that combine highly accurate and compact vacuum measurement and control in the smallest footprint.

## Industrial Processes

- **Thin Film Deposition**
  - glass coating equipment (architectural glass, automotive glass, flat panel display substrates)
  - thin film solar cells production (photo-voltaic)
  - optical data media (Compact Discs, Digital Versatile Discs, Magneto Optical Discs)
- **Magnetic storage media (hard discs, read heads)**
- **Surface treatments (functional, decorative)**
- **Optical coating (ophthalmic, precision opto-electronics)**
- **Roll/web coating on films or foils**

In order to assure that a thin film process (PVD/sputtering) is reproducible it is necessary to measure parameters that relate to total gas pressure, which is a function of gas density and temperature, and the partial pressure of the individual gas species. These vacuum parameters should be measured precisely both during pump down to base pressure and during processing as processing often releases gas into the deposition environment.

In crowded chambers at higher pressures (>1mTorr), significant pressure differential can exist in the processing chamber. These pressure differentials can affect film



*Plasma vapour deposition (PVD). Worker adjusting the controls of a PVD machine which is being used to coat components (trays at lower centre and lower left) with a thin film metal alloy to provide a wear-resistant coating.*

properties such as residual stress, composition, electrical resistivity, etc. In sputter deposition systems, when establishing a plasma, such pressure differences can change the plasma density and thus the sputtering rate, thereby affecting the film composition deposition. In such circumstances several gauges may be used at different locations in the processing chamber to monitor the pressure differences.

- **Device Processing**
  - TV and monitor picture tube manufacture
  - Evacuation and coating of lamps (motorway lighting, beamers)
  - X-Ray tubes & electron devices (CPI, etc)
  - Medical accelerator tubes (medical devices)
  - Lasers, night vision systems
  - Cryogenic processes and instrumentation
  - Infrared detectors (DRS)
- **General Industrial Processes**
  - Vacuum furnaces – Metallurgy

### Vacuum Furnaces for Metal Treatment

Brazing, sintering or annealing metals requires an atmosphere free of oxygen. Therefore, such processes are carried out under partial vacuum using inert gas. The vacuum level must be monitored and kept constantly low during the process in order to avoid oxidation of the products. As a result, it is necessary to measure the pressure in the high vacuum furnace near the gas inlet as well as at the vacuum port with high accuracy. Agilent active convection gauges with wide measuring range can detect the pressure at the furnace gas inlet and vacuum port with excellent precision. They are then linked to the system PLC by their serial port with either RS-232 or 485 communication. Based on this, all system pressure levels can be monitored at the main control system. This allows easy monitoring of the system gradient inside the furnace.



# VACUUM MEASUREMENT



Scanning electron microscopes, like the one shown here, can “see” details as small as one nanometre – one millionth of a metre!



An NRC researcher uses a liquid chromatography-mass spectrometry system to quantify toxins in shellfish samples.

## Nanotechnologies & Semiconductor Manufacturing

- **Electron Microscopy (SEM, TEM)**
- **Focused Ion-beam Systems (FIB) and Surface Analysis**
- **Semiconductor manufacturing**

Modern focused-beam systems such as SEMs, TEMs and FIB's utilize columns that project electrons or ions onto microscopic samples for detailed analysis. End users analyze all types of substances from organic compounds to semiconductor wafers. A key requirement is high sample throughput in order to lower the cost of ownership of these instruments. Agilent offers a full range of high and ultra-high vacuum gauges designed especially for the demanding requirements of SEMs, TEMs and surface analysis systems. Vacuum gauges are also a key component in modern focused-beam systems because the process gas flow can cause significant fluctuations in chamber pressures demanding a wide range of control. Agilent offers a full range of application specific SEM vacuum gauges for easy system integration and flexibility, or gauge controllers for systems that do not have integrated control systems or require dedicated remote read-out.

For the majority of semiconductor manufacturing processes, vacuum system operation usually can be enhanced through good vacuum control to improve reliability, throughput, uptime, contamination control, and process control. For example, a vacuum pump-down or purge cycle often can be shortened without degrading the product, and the time saved can significantly increase throughput. Agilent's complete line of on-board, direct measurement gauges can be easily integrated into existing OEM system controllers through digital or analog control, assuring the ability to meet demanding rapid cycle applications, such as vacuum load locks, in which high gas-load cycling and high tolerable foreline pressures are critical to the success of the process.

## Analytical Instrumentation

### • Mass Spectrometry

Mass Spectrometry has become an important analytical tool in many industries including pharmaceuticals and life sciences. Thanks to advances in electronics, instrument designers can implement cost-effective, high-performance analytical power in a cost-effective, easy-to-use system. These developments require advanced vacuum systems that are characterized by multi-chamber, high throughput designs on the high quality instruments.

Mass Spectrometers must operate with high accuracy and reliability. Periodic offset adjustment under fine vacuum conditions guarantees that even slightest hints of contamination can be detected. The precise Pirani vacuum transducer controls whether the required vacuum level for zero adjustment is achieved. With its elastic helix filament and the rugged metal housing the transducer is especially durable.

# AGILENT GAUGE CONTROLLER

## ▶ Agilent XGS-600



The XGS-600 Vacuum Gauge Controller provides unprecedented capacity, performance and flexibility in a cost effective, standard half-rack package. A single controller can simultaneously operate up to four hot filament (or four cold cathode) gauges and four convection gauges, up to five cold cathode gauges, or up to twelve convection gauges. Expansion or re-configuration in the field is easy to do. Serial communications (RS-232 or RS-485), sixteen set points,

and universal voltage compatibility are standard in all units. A programmable dot matrix LCD provides display flexibility, and simple screen organization and navigation makes the unit extremely easy to use. Drop down gauge selection automatically sets the emission current, sensitivity and overpressure. The screen displays up to eight gauges and pressures simultaneously, and permits the user to label each gauge. A large-font feature provides visibility from up to 20 feet.

### Features

### Benefits

<ul style="list-style-type: none"> <li>• Powerful</li> </ul>	<ul style="list-style-type: none"> <li>• A single unit can simultaneously operate up to:                             <ul style="list-style-type: none"> <li>– 4 BA and 4 convection gauges (or 4 IMG and 4 convection gauges)</li> <li>– 5 ion gauges (5 IMG gauges or 4 hot filament and 1 IMG)</li> <li>– 12 Convection gauges</li> <li>– 12 Agilent Active gauges</li> </ul> </li> <li>• 8 Open collector set points</li> <li>• 8 Contact relays</li> <li>• Standard Features in every unit:                             <ul style="list-style-type: none"> <li>– Serial communication (RS-232 and RS-485), universal voltage, Degas</li> </ul> </li> </ul>
<ul style="list-style-type: none"> <li>• Flexible</li> </ul>	<ul style="list-style-type: none"> <li>• Operates hot filament, inverted magnetron (cold cathode), convection gauges and all Agilent Active gauges</li> <li>• Can mix and match any gauges in a single unit</li> <li>• Can expand or reconfigure easily in the field</li> <li>• Optional card supports Profibus DP communications protocol</li> </ul>
<ul style="list-style-type: none"> <li>• Easy to Use</li> </ul>	<ul style="list-style-type: none"> <li>• Simple screen organization and navigation</li> <li>• Drop down gauge selection automatically sets the emission current, sensitivity and overpressure.</li> <li>• Displays up to 8 gauges simultaneously on one screen</li> <li>• Large font feature allows display of 2 gauges visible from 15-20 feet</li> <li>• Capability of programming your own 5 character gauge label</li> <li>• Set Point Screen: displays and adjusts set points for up to 8 gauges</li> </ul>
<ul style="list-style-type: none"> <li>• Fast</li> </ul>	<ul style="list-style-type: none"> <li>• &lt; 20 milliseconds from signal to set point response (Open collector only)</li> </ul>
<ul style="list-style-type: none"> <li>• Compact</li> </ul>	<ul style="list-style-type: none"> <li>• All in the impressively small half-rack package</li> </ul>



# VACUUM MEASUREMENT

XGS-600 Controller operates all Agilent gauges with only 3 gauge cards...  
convection, hot filament and cold cathode (inverted magnetron)

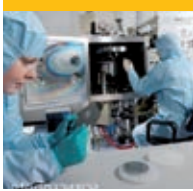

## Laboratory

- Easy to use – can be operated without a manual; screens and menus are easy to follow
- Easy to order – only 3 different controller gauge cards/modules to choose from, everything else is standard
- Easy to adapt – only one gauge card is needed to operate any Agilent gauge of a given type
- Practical – the XGS-600 can be easily reconfigured – it just takes a few minutes to add or remove a gauge card – any Agilent gauge can be operated in one unit
- Convenient – view up to 8 gauges at one time or change the font to view 2 from 15 feet away – all programming is stored in flash memory so no battery backups are needed

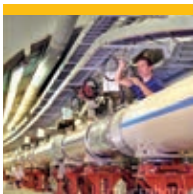

## Accelerators, Synchrotrons and Other Large Facilities

- Signal response – <20 milliseconds from signal to set point response – ideal for fast acting valves
- Capacity – operates up to 5 IMG gauges in one controller
- Compact – half-rack size saves up to 50-75% of rack space from other controller options
- Operability – fully programmable serial communications with individual gauge labeling; choice of RS-232/485
- Flexibility – combine UHV/HV metrology and IMG interlocking in one unit – ideal in beamline applications

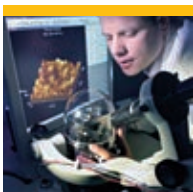

## OEM Equipment

- Reliable – The XGS-600 controller has been qualified under demanding test standards; thermal management reduces component stress and provides consistency and durability in performance
- Compact – half-rack size for up to 4 ion gauges and 4 convection gauges in one unit
- Flexibility – operates any Agilent gauge in one controller
- Performance – fully programmable serial communication is standard. Serial response time <2 milliseconds. Displays up to 8 gauges in one screen, gauge labeling. All programming stored in flash memory – no batteries needed
- Contact relay set points for maximum control flexibility and backwards compatibility with legacy controllers

## Possible Configurations

Below are examples of ways to configure the XGS-600, but remember, you are not limited to these configurations. The flexibility of this unit allows you to setup the controller with the gauges that suit your needs.

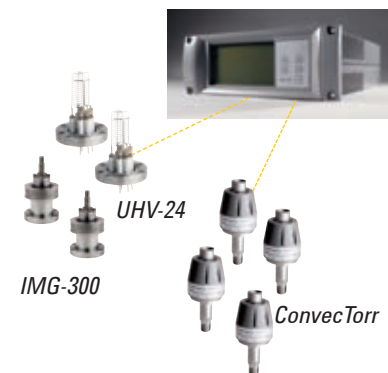

# AGILENT GAUGE CONTROLLER

## ▶ Agilent XGS-600 (Cont'd)

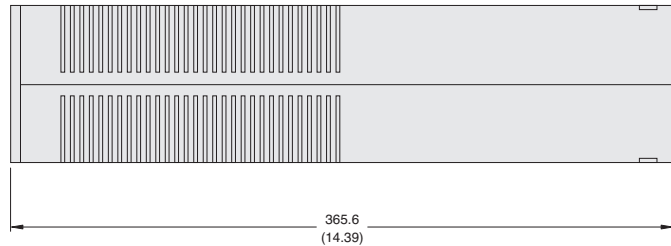
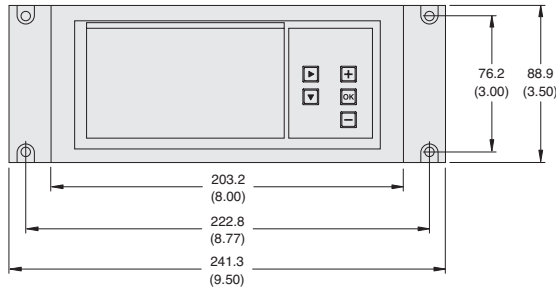

Dimensions: millimeters (inches)

## Technical Specifications

<b>User interface</b>	LCD monochrome dot matrix, 240 x 128, white LED backlight; 5 button keypad
<b>Display capability</b>	Up to eight simultaneous channels of pressure measurement, up to a 5 character user label for each; up to two channels in a large font; readable from 15 feet; display updates every 200 msec
<b>Gauge capability</b>	Up to 4 Hot Filament BA gauges including metal, glass, and nude UHV types using the HFIG** cards; up to 5 IMGs* using the IMG* cards; up to 12 rough gauges using the Dual Convection Gauge Cards; up to 12 Active Gauges using Dual Analog Input Cards
<b>Measurement range</b>	$1 \times 10^{-11}$ Torr to Atm dependent upon card and gauge type selected
<b>Set points - Open collector</b>	Eight normally open setpoints with independently programmable ON and OFF delays, manual override; fast response: 20 msec max (with delay set to 0.0 sec)
<b>Contact relays</b>	Eight normally open or normally closed mechanical relays with 24V @ 2 amp rating, using 25 pin D-sub with same pinout as MultiGauge/SenTorr; 2 set points per relay/channel
<b>Serial communications</b>	RS232 and RS485 (fully programmable)
<b>Analog outputs</b>	1v/dec LOG, 0 – 10 V FS, on each card with 200 msec update rate
<b>I/O control</b>	HFIG** card: Remote gauge ON/OFF, Fil select, DeGAS ON/OFF Inputs, Status Output IMG* card: Remote gauge ON/OFF Input, Status Output Dual Convection Card: Remote CAL inputs, Status Outputs Dual Analog Input Card: Remote CAL Inputs, Status Output
<b>Other</b>	Auto-ON capability for installed ion gauges when at least one convection card is installed Sensitivity, gas correction, emission current (BA gauges only) inputs for ion gauges E-BEAM degas, with auto turn off for BA gauges Selectable air or argon calibration for rough gauges Adjustable atmosphere value for rough gauges Text error messages All data stored in FLASH non-volatile memory requiring no batteries
<b>Power input / Temperature</b>	Worldwide universal power input, 100-240 VAC, 2 A, 50/60 Hz, IEC inlet; 5-40 °C ambient
<b>Regulatory approvals</b>	CE certified and RoHS compliant, BV certified for USA and Canada

\*IMG – Inverted Magnetron Gauge

\*\*HFIG – Hot Filament Ion Gauge

# VACUUM MEASUREMENT

## Ordering Information

Description	Part Number
XGS-600 Vacuum Controller, without cards	XGS600H0M0C0
Configure your XGS-600 Controller with cards – constructing your part number:	XGS600HXMXX
1 Refer to the Gauge Selection Chart to help determine the gauge you need	
2 Choose the number of HFIG** cards you want; place after the "H"; will be 0 to 4	
3 Choose the number of IMG* (cold cathode) cards you want; place after the "M"; will be 0 to 5	
4 Choose the number of Dual Convection Gauge Cards; place after the "C"; each card runs two convection type gauges, will be 0 to 6	
5. If ordering Active Gauge (Analog Input) Cards, add "Ax" to the end of the part number, with the number of cards desired (1 to 6). Each card operates two Active Gauges.	XGS600HXMXXAX

### NOTE:

- The XGS-600 has 6 gauge card slots permitting a total of 6 cards.
- Up to four slots can be used for HFIG\*\* cards. If four of these are chosen, one IMG\* card or up to two Dual Convection Gauge Cards may be selected also.
- Up to five slots can be used for IMG\* cards. If five of these are chosen, no additional gauge cards may be selected.
- All six slots may be used for Dual Convection Gauge Cards or Analog Input Cards.
- HFIG, IMG, and Dual Convection Cards can be used with Dual Analog Input Cards.

Cable Description	Length	Part Number							
		3 ft	10 ft	25 ft	50 ft	65 ft	75 ft	90 ft	100 ft
XGS-600 I/O, with flying leads			R32493010	R32493025	R32493050		Special Order (SO)		
ConvecTorr Gauge, non-bakeable			L91223010	L91223025	L91223050		Special Order (SO)		L91223100
Thermocouple Gauge (531, 536)			L91313010	L91313025	L91313050	SO	L91313075	SO	L91313100
MBA2-200 Gauge			X3203-60006	X3203-60007	X3203-60008	X3203-60009	X3203-60010	N/A	N/A
Glass BA Gauge standard, non-bakeable			R32443010	R32443025	R32443050		Not available over 50 feet –		
UHV-24/UHV-24p standard, non-bakeable			R32453010	R32453025	R32453050		with 10 ft. standard cable, it is possible		
UHV-24/UHV-24p Teflon UHV, bakeable to 250 °C			R32463010	R32463025	R32463050		to order extension up to 250 ft.		
Ion Gauge extension – all hot filament			N/A	N/A	N/A	R32473065	SO	R32473090	SO
IMG-100 Gauge, non-bakeable – may be used with IMG-300			R03113010	R03113025	R03113050	SO	R03113075	SO	R03113100
IMG-300 Gauge, bakeable			R03413010	R03413025	SO	R03413065	SO	SO	R03413100
CT-100 Analog Input Board	R35883003	R35883010	R35883025	R35883050					
FRG-700/PVG/PCG Analog Input Board	R35893003	R35893010	R35893025	R35893050					
CDG Analog Input Board	R35903003	R35903010	R35903025	R35903050					
FRG720/730 Analog Input Board	R35913003	R35913010	R35913025	R35913050					

### Accessories

Description	Part Number
Hot Filament Ion Gauge (HFIG) card, field Install	R3075301
Inverted Magnetron Ion Gauge (IMG) Card, field install	R3080301
Dual Convection Gauge Card, field install	R3084301
Dual Analog Input Card, field install	R3487301
Tilt stand accessory	R3124301
Center rack mount kit	L6423301
Off-Center rack mount kit	L6422301
Dual Mount rack mount kit	L6426301

\*IMG – Inverted Magnetron Gauge

\*\*HFIG – Hot Filament Ion Gauge

### Power Cord Selection

One power cord included with each unit

Description	Part Number
Europe, 10 A / 220-230 VAC, 2.5 meter	656494220
Denmark, 10 A / 220-230 VAC, 2.5 meter	656494225
Switzerland, 10 A / 230 VAC, 2.5 meter	656494235
UK/Ireland, 13 A / 230 VAC, 2.5 meter	656494250
India, 10 A / 220-250 VAC, 2.5 meter	656494245
Israel, 10 A / 230 VAC, 2.5 meter	656494230
Japan, 12 A / 100 VAC, 2.3 meter	656494240
North America, 13 A / 125 VAC, 2.0 meter	656458203

## AGILENT GAUGES – ROUGH VACUUM

### ► Agilent ConvecTorr Gauge

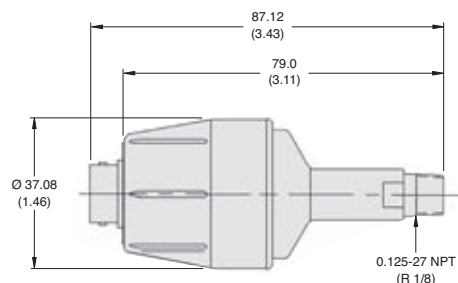

Dimensions: millimeters (inches)

Agilent's unique ConvecTorr gauge is a stainless steel, convection-enhanced thermal gauge, which maintains the sensing element at a constant temperature for superior performance from  $10^{-4}$  Torr to atmospheric pressure. The ConvecTorr features accurate pressure indication over the entire rough vacuum range with extremely fast response time (0.2 seconds) and superior readings at higher vacuum pressures due to enhanced thermal stability. ConvecTorr is ideally suited for a wide range of demanding vacuum applications where accurate pressure monitoring and rapid, repetitive pump downs from atmosphere are required, such as load lock applications or control of a two-stage pump down. And, with excellent sensitivity near atmospheric pressure, ConvecTorr can often save many hours of pumping time when monitoring initial pumping of large vacuum systems.

The ConvecTorr, unlike other convection-type gauges, is not affected by system vibration and features a locking bayonet connector. The ConvecTorr offers continuous and repeatable pressure indications between 0 °C and 50 °C. The ConvecTorr is offered with a variety of mounting options and is easily interfaced with Agilent's XGS-600 gauge controller for integration in a complex vacuum system, or for use as a stand-alone pressure measurement tool.

### Ordering Information

Description	Part Number	Fitting	Shipping Weight kg (lbs)
ConvecTorr Gauge Tube, platinel filament	L9090301	½ in. NPT	0.5 (1.0)
	L9090302	Mini-ConFlat	0.5 (1.0)
	L9090303	Cajon 4 VCR (female)	0.5 (1.0)
	L9090305	NW16 KF	0.5 (1.0)
	L9090306	NW25 KF	0.5 (1.0)

### Technical Specifications

#### Measurement range

$1 \times 10^{-4}$  Torr to atmosphere,  $1 \times 10^{-1}$  to 133 Pascal

#### Measurement precision

+ 30 % within a pressure decade

#### Temperature limits

Operating: 0 °C to 50 °C; storage: -15 to 80 °C; bake out: 80 °C with cable disconnected

#### Pressure response time

Less than 0.2 seconds

#### Materials

304 stainless steel with platinel filament and ABS housing



# VACUUM MEASUREMENT

## ▶ Agilent 531 Thermocouple and 536 Baffled Thermocouple

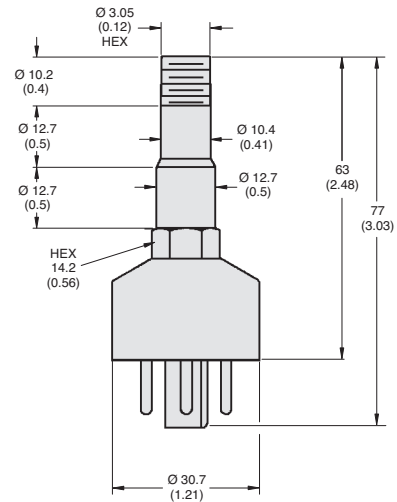

Dimensions: millimeters (inches))

The 531 Thermocouple Gauge Tube is the time-proven, low-cost solution (nickel-plated, soldered construction) for continuous and accurate indication of rough vacuum pressure from  $1 \times 10^{-3}$  to 2.0 Torr ( $1 \times 10^{-3}$  mbar to 2.7 mbar). Featuring rugged dependability and consistent operation unaffected by mounting orientation.

The 536 Thermocouple Gauge Tube is a welded 304 stainless steel version of the 531 with an additional baffle that greatly extends the sensor life when exposed to condensable gases in demanding applications. It provides a continuous and repeatable indication of pressures from  $1 \times 10^{-3}$  Torr to 2 Torr ( $1 \times 10^{-3}$  mbar to 2.7 mbar). The thermocouple and heater are noble metal to minimize any possible affect of contaminants on gauge performance.

Both gauges are offered in a variety of mounting options and are easily interfaced with Agilent's XGS-600 gauge controller.

### Technical Specifications

#### Measurement range

$1 \times 10^{-3}$  Torr to atmosphere,  $1 \times 10^{-1}$  to 133 Pascal

#### Temperature limits

Operating: 0 °C to 50 °C; Storage: -15 to 80 °C; bake out: 150 °C with cable disconnected

#### Pressure response time

Less than 3 seconds

### Ordering Information

Description	Part Number	Fitting	Weight kg (lbs)
<b>531 Thermocouple Gauge Tube</b>	F0472301	½ in. NPT	0.5 (1.0)
<b>536 Thermocouple Gauge Tube</b>			
Baffled TC tube type 304 stainless steel	L6141303	½ in. NPT	0.5 (1.0)
Platinel filament	L6141304	Mini-ConFlat	0.5 (1.0)
	L6141305	Cajon 4 VCR (female)	0.5 (1.0)
	L6141307	NW10 KF	0.5 (1.0)
	L6141308	NW16 KF	0.5 (1.0)
	L6141309	NW25 KF	0.5 (1.0)

## AGILENT GAUGES – HIGH VACUUM

### ▶ Agilent Thermocouple and ConvecTorr Gauge Simulators – Rough Vacuum



**TC Gauge Simulator**

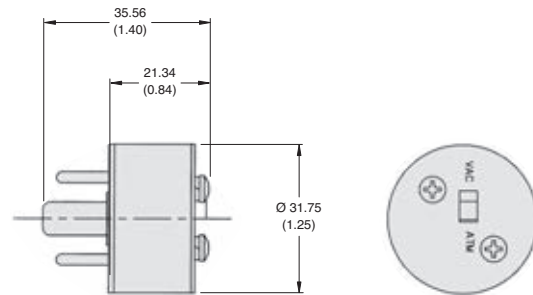

**ConvecTorr Simulator**

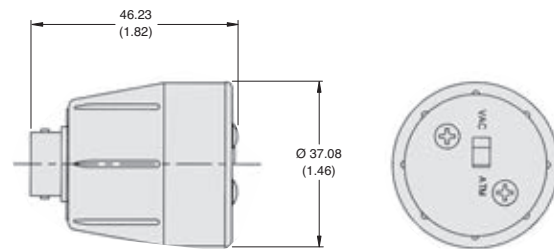

ConvecTorr and TC Gauge Simulators are designed to be convenient tools for verifying proper operation of the control unit. For those cases when the target gauge tube cannot be brought to proper pressure levels for true in-situ calibration, the simulator is used to ensure the control unit is calibrated to the average tube. The selectable “Vac” or “Atm” setting facilitates troubleshooting.

*Dimensions: millimeters (inches)*

### Technical Specifications

#### Reference pressure

Simulates high vacuum  $<10^{-4}$  Torr and atmosphere 760 Torr

### Ordering Information

Description	Part Number	Shipping Weight kg (lbs)
ConvecTorr Simulator	L7382301	0.5 (1.0)
TC Simulator	L7383301	0.5 (1.0)

# VACUUM MEASUREMENT

## ▶ Agilent 572 Dual Tungsten Filament Bayard-Alpert Type Standard Range Ionization Gauge Tube

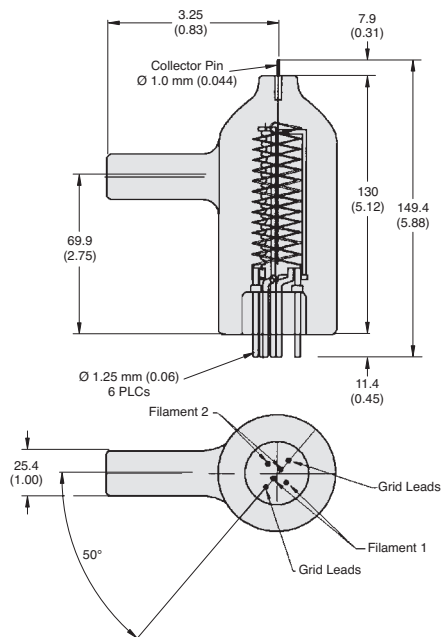

Dimensions: millimeters (inches)

The 572 is a high-performance gauge with a wide range of linear response: from  $2 \times 10^{-10}$  to  $10^{-3}$  Torr. It is designed to withstand long periods of outgassing, and to facilitate simple external switching of filaments without disturbing the vacuum system. The 572 is compatible with virtually all modern hot filament ionization gauge controllers.

### Technical Specifications

#### Sensitivity

$10 \text{ (Torr)}^{-1} \text{ (mbar)}^{-1}$  (typical)

#### Operating ratings

- 0 VDC to ground (collector)
- + 180 VDC to ground (grid)
- + 30 VDC to ground (filament)

#### X-Ray limit

$2 \times 10^{-10}$  Torr, ( $2.6 \times 10^{-10}$  mbar)

#### Operating pressure

$2 \times 10^{-10}$  Torr to  $1 \times 10^{-3}$  Torr  
( $2.7 \times 10^{-10}$  mbar to  $1 \times 10^{-3}$  mbar)

### Ordering Information

Description	Part Number	Fitting	Shipping Weight kg (lbs)
572 Dual-tungsten-filament ionization gauge tube	K7360301	1 in. Glass tubulation	0.5 (1.0)
	K7360302	1 in. Kovar tubulation	0.5 (1.0)
	K7360303	¾ in. Glass tubulation	0.5 (1.0)
	K7360304	¾ in. Kovar tubulation	0.5 (1.0)
	K7360305	NW25 KF	0.5 (1.0)
	K7360306	NW40 KF	0.5 (1.0)
	K7360307	2.75 in. CFF	0.5 (1.0)

## AGILENT GAUGES – HIGH VACUUM

### ▶ Agilent 571 Series Bayard-Alpert Type Standard Range Ionization Gauge Tube

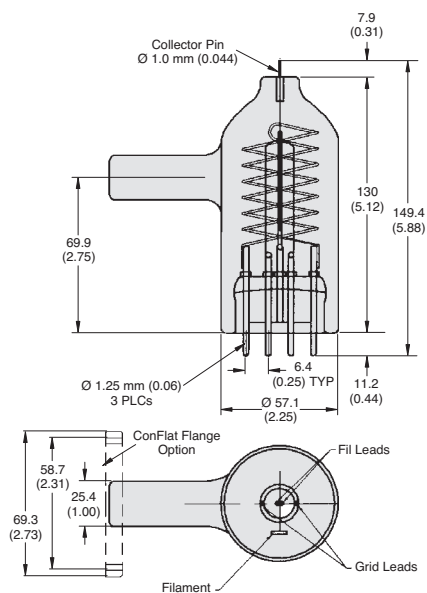

Dimensions: millimeters (inches)

The 571 offers high performance and wide range ( $2 \times 10^{-10}$  to  $1 \times 10^{-3}$  Torr). The gauge is rugged; it can withstand long periods of degassing or accidental exposure to atmosphere at operating temperature and still recover its original characteristics.

#### Technical Specifications

##### Sensitivity

$6 \text{ (Torr)}^{-1} \text{ (mbar)}^{-1}$  (typical)

##### Operating ratings

- 0 VDC to ground (collector)
- 0 VDC (shield)
- + 180 VDC to ground (grid)
- + 30 VDC to ground
- 4.0 VAC nominal (filament)

##### X-Ray limit

$4 \times 10^{-10}$  Torr, ( $5.2 \times 10^{-10}$  mbar)

##### Operating pressure

- $4 \times 10^{-10}$  Torr to  $5 \times 10^{-2}$  Torr  
( $5 \times 10^{-10}$  mbar to  $6.7 \times 10^{-2}$  mbar) (Air)
- $4 \times 10^{-10}$  Torr to  $1 \times 10^{-1}$  Torr  
( $5 \times 10^{-10}$  mbar to  $1 \times 10^{-1}$  mbar) (Argon)

#### Ordering Information

Description	Part Number	Fitting	Shipping Weight kg (lbs)
571 Ionization tube with thoria-coated iridium filament	K2471301	1 in. Glass tubulation	0.5 (1.0)
	K2471302	1 in. Kovar tubulation	0.5 (1.0)
	K2471304	¾ in. Glass tubulation	0.5 (1.0)
	K2471305	¾ in. Kovar tubulation	0.5 (1.0)
	K2471306	NW25 KF	0.5 (1.0)
	K2471311	NW40 KF	1.0 (2.0)
	K2471303	2.75 in. CFF	1.0 (2.0)
	K2471307	–	0.5 (1.0)
571 reference ionization tube with thoria-coated iridium filament (sealed off at $\leq 5 \times 10^{-6}$ Torr)	K2471307	–	0.5 (1.0)



# VACUUM MEASUREMENT

## ▶ Agilent 563 Series Bayard-Alpert Type Standard Range Ionization Gauge Tube

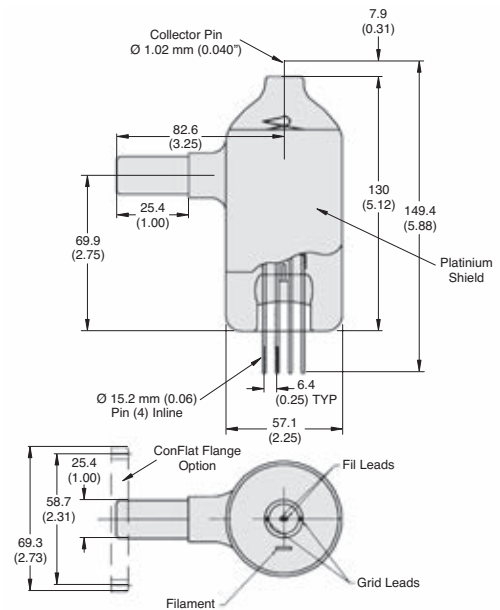

Dimensions: millimeters (inches)

The 563 is a rugged gauge with wide range of linear response:  $2 \times 10^{-10}$  to  $1 \times 10^{-3}$  Torr. The platinum coating inside the bulb shields the gauge elements from electrostatic charges at low pressures and drains off the static charges which can build up at high pressures. The 563 is available in a variety of tubulations.

### Technical Specifications

#### Sensitivity

$10 \text{ (Torr)}^{-1} \text{ (mbar)}^{-1}$  (typical)

Exact measurement available through Agilent STARRS program.  
Contact Agilent for details

#### Operating ratings

- 0 VDC (collector)
- + 180 VDC to ground (grid)
- + 30 VDC to ground
- 5 VAC nominal (filament)

#### X-Ray limit

$2 \times 10^{-10}$  Torr, ( $2.6 \times 10^{-10}$  mbar)

#### Operating pressure

$2 \times 10^{-10}$  Torr to  $1 \times 10^{-3}$  Torr  
( $2.7 \times 10^{-10}$  mbar to  $1 \times 10^{-3}$  mbar)

### Ordering Information

Description	Part Number	Fitting	Shipping Weight kg (lbs)
563 Ionization tube with thoria-coated iridium filament	K2466301	1 in. Glass tubulation	0.5 (1.0)
	K2466302	1 in. Kovar tubulation	0.5 (1.0)
	K2466304	¾ in. Glass tubulation	0.5 (1.0)
	K2466305	¾ in. Kovar tubulation	0.5 (1.0)
	K2466306	NW25 KF	0.5 (1.0)
	K2466311	NW40 KF	1.0 (2.0)
	K2466303	2.75 in. CFF	1.0 (2.0)
	K2466307	—	0.5 (1.0)
563 reference ionization tube with thoria-coated iridium filament (sealed off at $\leq 5 \times 10^{-6}$ Torr)	K2466307	—	0.5 (1.0)

# AGILENT GAUGES – HIGH VACUUM

## ▶ Agilent MBA2-200 Hot Filament Gauges

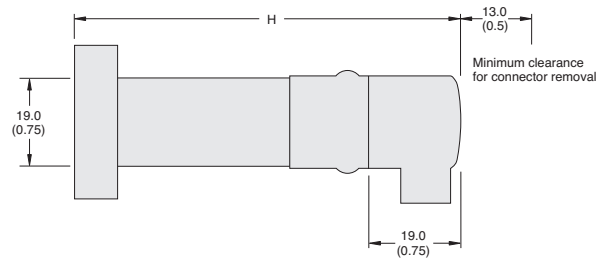

Fitting	H
KF flange	73 (2.9)
ConFlat flange	73 (2.9)

*ID Shown - ID of CF & KF Flanges as per international standards*

*Dimensions: millimeters (inches)*

Agilent MBA2-200 Hot Filament Gauges are the smallest Bayard-Alpert style gauges. They are rugged with wide range, they generate low heat and provide good burnout resistance. The MBA2-200 Gauge is small (less than 5% of the volume of a glass gauge) and mounts in almost any location on your system. Its all-metal design eliminates the possibility of breakage. The MBA2-200's unique dual ion collectors and metal envelope provide measurement up to  $5 \times 10^{-2}$  Torr and it has an x ray limit equivalent to that of a glass gauge ( $3 \times 10^{-10}$  Torr).

Dual, burn-out resistant, yttria-coated iridium filaments provide long life. As a result, you can avoid unscheduled downtime by using the second filament as a backup until the gauge can be replaced during regular maintenance procedures. In addition, an MBA2-200 gauge requires only 8% of the power of a glass gauge, which means less heat to potentially disturb a process or experiment, cause accidental burns, or melt wiring that may come in contact with the gauge.

### Technical Specifications

<b>Mounting orientation</b>	Any
<b>Materials</b>	Vacuum fired, UHV compatible
<b>Envelope</b>	304L stainless steel
<b>Collector</b>	Tungsten
<b>Grid</b>	Tantalum
<b>Filaments</b>	Tungsten or yttria-coated iridium
<b>Weight</b>	0.1 kg (4 oz.) with 1.33 in ConFlat flange (NW 16CF)
<b>Internal volume</b>	10.8 cm <sup>3</sup> (0.66 in. <sup>3</sup> )
<b>X ray limit</b>	$3 \times 10^{-10}$ Torr ( $3.99 \times 10^{-10}$ mbar, $3.99 \times 10^{-8}$ Pa) maximum
<b>Sensitivity for N<sub>2</sub></b>	20/Torr (15/mbar, 0.15/Pa)
<b>Electron bombardment degas</b>	3 W at 250 to 330 V
<b>Bakeout temperature, nonoperating</b>	200 °C (392 °F) maximum with cable disconnected 150 °C (302 °F) maximum with cable connected
<b>Operating temperature</b>	0 to 50 °C (32 to 122 °F) ambient, noncondensing
<b>Filament emission current</b>	4 mA maximum 15 mA for electron bombardment degas
<b>Filament bias potential</b>	+30 V
<b>Filament heating voltage</b>	1.2 V (2.3 V maximum)
<b>Filament heating current</b>	2.0 A (3.0 A maximum)
<b>Collector potential</b>	0 V
<b>Grid potential</b>	+180 V

### Ordering Information

Description	Part Number
MBA2-200T, Dual Tungsten Fils, NW25	X3203-60000
MBA2-200T, Dual Tungsten Fils, NW40	X3203-60001
MBA2-200T, Dual Tungsten Fils, CFF2.75	X3203-60002
MBA2-200, Dual Yttria-Iridium Fils, NW25	X3203-60003
MBA2-200, Dual Yttria-Iridium Fils, NW40	X3203-60004
MBA2-200, Dual Yttria-Iridium Fils, 2.75Cff	X3203-60005
Cable, 10', MBA2 HFIG, XGS-600	X3203-60006
Cable, 25', MBA2 HFIG, XGS-600	X3203-60007
Cable, 50', MBA2 HFIG, XGS-600	X3203-60008
Cable, 65', MBA2 HFIG, XGS-600	X3203-60009
Cable, 75', MBA2 HFIG, XGS-600	X3203-60010

# VACUUM MEASUREMENT

## ▶ Agilent IMG-100 Inverted Magnetron Gauge

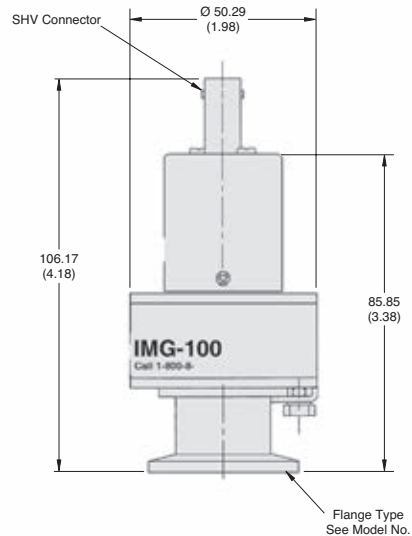

The IMG-100 is a rugged and accurate high vacuum gauge featuring a wide measurement range, fast starting time, good accuracy and superior repeatability in challenging environments. The IMG-100 is ideal for use in industrial applications such as metal deposition, glass coaters, vacuum furnaces, degassing ovens, and electron-beam welders. The simple design requires no heated filament, so the IMG-100 has an excellent lifetime, is easily serviced, and is tolerant of sudden or frequent exposure to atmosphere. Further, there is less risk of heat from the gauge interfering with a critical experiment or process. The compact size allows flexible installation in any orientation, while the locking SHV high-voltage connector ensures safety and positive electrical contact. A precisely designed magnetic field constrains ionized gas molecules for accurate pressure measurement, so emission of stray electrons and photons is minimized.

The IMG-100 is easily interfaced with Agilent's XGS-600 gauge controller for integration into a variety of vacuum systems, or for use as a stand-alone pressure measurement tool.

### Technical Specifications

#### Measurement range

$1 \times 10^{-3}$  Torr to  $5 \times 10^{-9}$  Torr,  $1 \times 10^{-1}$  Torr to  $7 \times 10^{-7}$  Pascal

#### Measurement precision

+ xx % within a pressure decade standard, + xx % with STARRS Calibration

#### Temperature limits

Operating: 0 °C to 80 °C; storage: -15 to 80 °C

#### Bake out temperature with Conflat flange

150 °C maximum with Cable Disconnected

#### Ignition response (starting time)

T < 5 seconds at pressures <  $1 \times 10^{-6}$  Torr

#### Materials exposed to vacuum

300 series stainless steel, nickel, glass (feedthrough)

#### Operating voltage

3 kilovolts

#### Sensitivity

2.7 A / Torr + 20% at  $5 \times 10^{-6}$  Torr

### Ordering Information

Description	Part Number	Shipping Weight kg (lbs)
IMG-100 NW25 KF	R0310301	1.0 (2.0)
IMG-100 NW40 KF	R0310302	1.0 (2.0)
IMG-100 2.75 in. CFF	R0310303	1.0 (2.0)

# AGILENT GAUGES – ULTRA-HIGH VACUUM

## ▶ Agilent IMG-300 UHV Inverted Magnetron Gauge

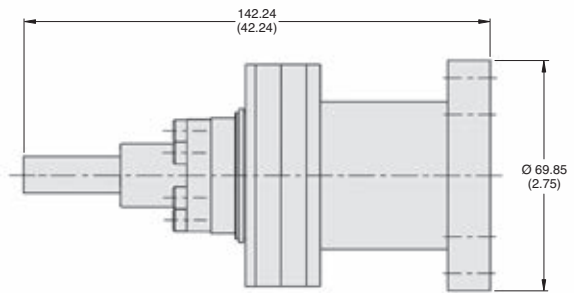

w/2.75 CFF

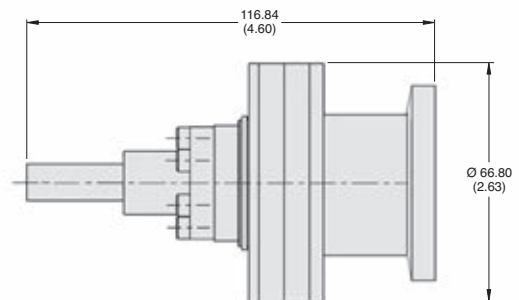

w/NW40 Flange

Dimensions: millimeters (inches)

The IMG-300 inverted magnetron gauge combines excellent ultra-high vacuum measurement capability with fast pressure response. This sensor is optimized for UHV applications such as particle accelerators, synchrotron light beam lines and energy research applications, where stable UHV pressure measurement and fast pressure response are equally critical. Inverted magnetron gauges have no x-ray limit, so the ability to read extremely low pressure is limited only by the number of gas molecules present.

The magnetic design provides superior sensitivity at UHV pressures and ensures starting within 30 seconds at  $1 \times 10^{-10}$  Torr (millibar). With no hot filament, there is minimal outgassing from within the gauge that would degrade absolute accuracy of pressure response, and there is no electron or photon emission to disrupt an experimental process.

The all-metal gauge design is radiation-resistant and bakeable to 250 °C during operation, while the locking SHV high-voltage connector ensures safety and positive electrical contact. Radiation-resistant, bakeable cables are also available. The IMG-300 is easily interfaced with Agilent’s XGS-600 gauge controller for integration into a variety of vacuum systems, or for use as a stand-alone pressure measurement tool.

### Technical Specifications

<b>Measurement range</b>
$1 \times 10^{-3}$ Torr to $1 \times 10^{-11}$ Torr, $1 \times 10^{-1}$ Torr to $1 \times 10^{-9}$ Pascal
<b>Measurement precision</b>
+ 50 % within a pressure decade standard, + 20 % with STARRS Calibration
<b>Temperature limits</b>
Operating: 0 °C to 250 °C; storage: -15 to 80 °C
<b>Bake out temperature</b>
250 °C maximum with cable and magnet attached

<b>Pressure response time</b>
< 50 milliseconds @ UHV pressures
<b>Ignition response (starting time)</b>
< 30 seconds @ $1 \times 10^{-10}$ Torr
<b>Operating voltage</b>
3 kilovolts
<b>Materials exposed to vacuum</b>
Stainless steel, nickel, glass, nickel alloy 52
<b>Sensitivity</b>
2 A / Torr + 20% at $5 \times 10^{-6}$ Torr

### Ordering Information

**NOTE** For information on compatible gauge controllers and cabling, please refer to Multi-Gauge sections of catalog.

Description	Part Number	Fitting	Shipping Weight kg (lbs)
IMG-300	R0343301	2.75 inch CFF	1.0 (2.0)



# VACUUM MEASUREMENT

## ► Agilent UHV-24 and UHV-24p Bayard-Alpert Ion Gauge

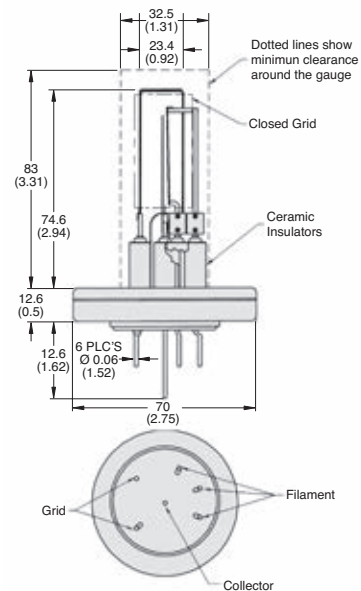
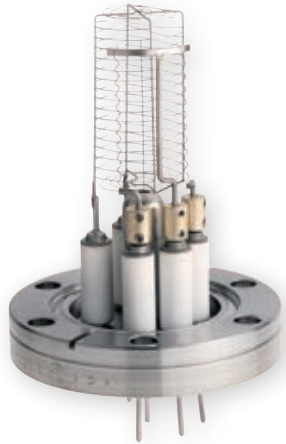

Dimensions: millimeters (inches)

The UHV-24 is a Bayard-Alpert ion gauge using Agilent's etched-grid structure to provide a broad operating pressure range with ionization effectiveness (sensitivity) at least 2 times that of other ionization gauges. The UHV-24 gauges excel in applications where superior measurement accuracy and repeatability of measurement are equally critical. The heated filament provides a constant source of electrons for ionization of gas molecules resulting in accurate and stable results. The precision collector limits X-ray current to a pressure equivalent of approximately  $5 \times 10^{-12}$  Torr ( $6.7 \times 10^{-12}$  mbar).

The UHV-24P, an extended range version of the UHV-24, measures pressure from  $5 \times 10^{-12}$  Torr to  $1 \times 10^{-3}$  Torr

( $6.7 \times 10^{-12}$  mbar to  $1 \times 10^{-3}$  mbar). The UHV-24 and 24P feature a 2-3/4-inch ConFlat flange with long-life thoria-coated iridium or tungsten filaments that are easily replaceable in the field.

The UHV-24 and 24P are easily interfaced with Agilent's XGS-600 gauge controller for integration into a variety of vacuum systems, or for use as a stand-alone pressure measurement tool.

### Technical Specifications

	UHV-24	UHV-24p
<b>Pressure range</b>	$2 \times 10^{-11}$ to $1 \times 10^{-3}$ Torr $2 \times 10^{-11}$ to $1 \times 10^{-3}$ mbar	$5 \times 10^{-12}$ to $1 \times 10^{-3}$ Torr $6.7 \times 10^{-12}$ to $1 \times 10^{-3}$ mbar
<b>Sensitivity</b>	25 Torr <sup>-1</sup>	20 Torr <sup>-1</sup>
<b>X-Ray limit</b>	$2 \times 10^{-11}$ Torr	$5 \times 10^{-12}$ Torr ( $6.7 \times 10^{-12}$ )
<b>Measurement precision</b>	+ 20% of full scale within a pressure decade	
<b>Emission current</b>	4 milliamps default (10 A to 9.99 mA)	
<b>Bake temperature</b>	450 °C with cable connected	
<b>Temperature limits</b>	Operation 0 °C to 250 °C; storage -15 to 80 °C	
<b>Degas</b>	Electron bombardment 400 volts @ 65 mA	
<b>Materials</b>	304 ST, ceramic, Kovar, iridium or tungsten	

### Ordering Information

Description	Part Number	Fitting	Shipping Weight kg (lbs)
UHV-24, dual tungsten filaments	9715008	2.75 in. CFF	2.0 (4.0)
UHV-24, dual thoria-iridium filaments	9715007	2.75 in. CFF	2.0 (4.0)
UHV-24P Extended Range, dual tungsten filaments	9715014	2.75 in. CFF	2.0 (4.0)
UHV-24P Extended Range, dual thoria-iridium filaments	9715015	2.75 in. CFF	2.0 (4.0)
Filament replacement kit (thoria-iridium)	9710028		0.5 (1.0)
Filament replacement kit (tungsten filament)	9710018		0.5 (1.0)

# ACTIVE GAUGES

## ▶ Agilent PVG-500/PVG-500S/PVG-502S Pirani Gauges

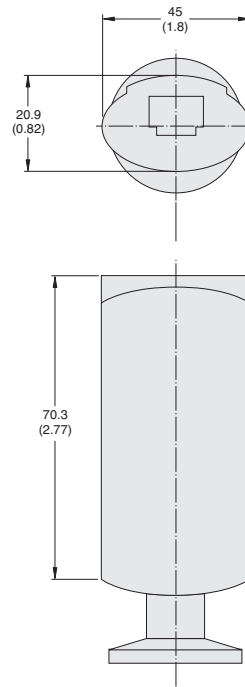

Dimensions: millimeters (inches)

The Agilent PVG-500 series of Pirani gauges provides the ultimate combination of state-of-art technology and ruggedness within a compact design. The PVG-500 series utilizes the most advanced digital Pirani technology combined with a stainless steel sensor design to meet the various needs of the market today.

### Applications

- Fore pressure vacuum pressure monitoring
- Controlling high vacuum ionization gauges
- Safety monitoring in vacuum systems
- General vacuum measurement and control in the medium and rough vacuum range

### Features

- Compact, rugged aluminum housing that mounts in any orientation with a logarithmic signal output
- Stainless steel sensor cell with metal-sealed feedthrough
- Easy push button ATM and High Vacuum (HV) adjustment
- Nickel filament option
- Optional set points

### Benefits

- Ease of integration
- Rugged design for a wide range of applications
- Ease of set-up
- Solution for corrosive applications
- Utilize pressure readings to perform critical operations

# VACUUM MEASUREMENT

## Technical Specifications

<b>Measurement range</b> (Air, O <sub>2</sub> , CO, N <sub>2</sub> )	5 x 10 <sup>-4</sup> to 1000 mbar (3.75 x 10 <sup>-4</sup> to 750 Torr)		
<b>Accuracy</b> (N <sub>2</sub> )	<b>% of reading</b>	<b>Units</b>	
	±15%	1 x 10 <sup>-3</sup> to 100 mbar (1 x 10 <sup>-3</sup> to 75 Torr)	
	±50%	5 x 10 <sup>-4</sup> to 1 x 10 <sup>-3</sup> mbar (3.75 x 10 <sup>-4</sup> to 1 x 10 <sup>-3</sup> Torr)	
	±50%	100 to 1000 mbar (75 to 750 Torr)	
<b>Repeatability</b> (Air)	1 x 10 <sup>-3</sup> to 100 mbar (1 x 10 <sup>-3</sup> to 75 Torr) – % of reading 62%		
<b>Output signal</b> (measurement signal)	<b>Voltage range</b> 0 to 10.3 V	<b>Measurement range</b> 1.9 to 10.0 V	
<b>Voltage vs. pressure</b>	1.286 V/decade, logarithmic		
<b>Error signal</b>	0 to 0.5 V (filament rupture)		
<b>Minimum loaded impedance</b>	10 kΩ, short-circuit proof		
<b>Response time</b>	80 ms		
<b>Adjustment</b>	One tactile switch for both ATM and HV adjustment		
<b>Identification gauge</b>	27 kΩ, referenced to supply common		
	<b>PVG-500</b>	<b>PVG-500S, PVG-502S</b>	
<b>Setpoint</b>	None	2	
<b>Setting range</b>	None	2 x 10 <sup>-3</sup> to 500 mbar (1.5 x 10 <sup>-3</sup> to 375 Torr)	
<b>Hysteresis</b>	None	10% above lower threshold % of reading	
<b>Relay contact</b>	None	30 VDC / 0.5 ADC floating	
<b>Switching time</b>	None	<20 ms	
<b>Supply voltage</b>	<b>At gauge</b> 14 to 30 VDC	<b>Ripple</b> ≤1 V <sub>pp</sub>	<b>Power consumption</b> ≤1 W
<b>Electrical connection</b>	FCC 68/RJ45 appliance connector, 8 poles, male		
<b>Sensor cable</b>	8 poles plus shielding		
<b>Cable length</b>	≤100 meter (330 ft)		
<b>Materials exposed to vacuum</b>	Glass, Ni, NiFe, tungsten (tungsten version)		
<b>Admissible temperature</b>	<b>Operation</b> 5 to 60 °C	<b>Storage</b> –20 to +65 °C	<b>Vacuum Connection</b> <sup>1</sup> 80 °C
<b>Mounting orientation</b>	Any		
<b>Weight</b>	80 g		

<sup>1</sup> In horizontal mounting position

## Ordering Information

Description	Part Number
PVG-500 Pirani, KF16	PVG500KF16
PVG-500 Pirani tungsten filament with setpoints, KF16	PVG500KF16S
PVG-502 Pirani nickel filament with setpoints, KF16 – for corrosive applications	PVG502KF16S
<b>Accessories</b>	
PVG-500 Replacement sensor (tungsten) – recommended for most applications	PVG500KF16RS
PVG-502 Replacement sensor (nickel) – recommended for corrosive applications	PVG502KF16RS

# ACTIVE GAUGES

## ▶ Agilent CDG-500 Capacitance Diaphragm Gauge

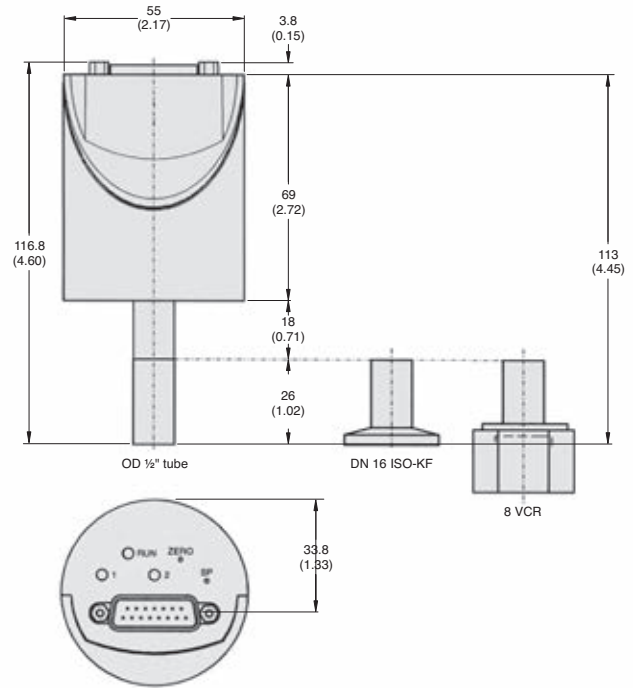

Dimensions: millimeters (inches)

The Agilent CDG-500 series of temperature compensated Capacitance Diaphragm gauges provides a high level of accuracy in the high pressure region. Full scale measurement ranges are available from 1000 Torr to 1 Torr. The CDG-500 series uses a corrosion resistant ultra pure alumina ceramic diaphragm providing exceptional signal stability, fast recovery from atmosphere, short warm-up times and unparalleled robustness.

### Features

- Full scale ranges from 1 to 1000 Torr with push button zeroing and optional set point control
- Excellent long term signal stability and repeatability
- Fast recovery from atmospheric pressures and rapid stabilization after start-up
- Corrosion resistant ceramic sensor with sensor shielding protection

### Applications

- General thin film and vacuum processes
- Industrial vacuum processes
- Data storage and display manufacturing
- Etch, CVD, PVD and other semiconductor production processes
- Reference sensor for monitoring of test instruments
- Transfer standard for traceability measurements

### Benefits

- Ease of integration
- Long term performance – comparable to competitor’s heated versions
- Reduces process cycle times
- Application robustness

# VACUUM MEASUREMENT

## Technical Specifications

<b>Measurement range</b> (full scale)	Torr	1000	100	10	1	
	Pa	133,322	13,332	1,333	133	
	mbar	1333	133	13.3	1.3	
<b>Accuracy</b> <sup>1</sup>	% of reading	0.2	0.2	0.2	0.2	
<b>Temperature effect</b>	on zero	% F.S./°C	0.005	0.005	0.005	0.015
	on span	% of reading/°C	0.01	0.01	0.01	0.01
<b>Resolution</b>	% F.S.	0.003	0.003	0.003	0.003	
<b>Pressure, maximum</b>	kPa (absolute)	400	260	260	260	
<b>Lowest reading</b>	% F.S.	0.01				
<b>Lowest suggested reading</b>	% F.S.	0.05				
<b>Lowest suggested control pressure</b>	% F.S.	0.05				
<b>Temperature</b>		<b>Operation</b> (ambient) 5 to 50 °C	<b>Bakeout</b> (at flange) <sup>2</sup> ≤ 110 °C	<b>Storage</b> -40 to 65 °C		
<b>Supply voltage</b>			14 to 30 VDC			
<b>Power consumption</b>			≤ 1 W			
<b>Output signal</b> (analog)			0 to 10 VDC			
<b>Response time</b>			30 ms			
<b>Degree of protection</b>			IP30			
<b>Electrical connection</b>			D-sub, 15 pole, male			
<b>Setpoints</b> <sup>3</sup> – Two (2) setpoints, SP 1 and SP 2		<b>Relay Contact</b> 30 VDC; ≤ 0.5 ADC	<b>Hysteresis</b> 1% of F.S			
<b>Materials exposed to vacuum</b>		Aluminum oxide ceramic (Al <sub>2</sub> O <sub>3</sub> ), Vacon 70 <sup>4</sup> , stainless steel (AISI 316L <sup>5</sup> ) AgCuTi hard solder, sealing glass				

<sup>1</sup> Non-linearity, hysteresis, repeatability at 25 °C ambient operating temperature without temperature effects after 2 hours operation

<sup>2</sup> Non operating

<sup>3</sup> CDG-500 setpoint versions only

<sup>4</sup> 28% Ni, 23% Co, 49% Fe

<sup>5</sup> 18% Cr, 10% Ni, 3% Mo, 69% Fe

## Ordering Information

Description	Part Number	
	KF16	VCR8
CDG-500 Capacitance Diaphragm Gauge (1000 Torr)	CDG500T1000KF16	CDG500T1000VCR8
CDG-500 Capacitance Diaphragm Gauge (100 Torr)	CDG500T0100KF16	CDG500T0100VCR8
CDG-500 Capacitance Diaphragm Gauge (10 Torr)	CDG500T0010KF16	CDG500T0010VCR8
CDG-500 Capacitance Diaphragm Gauge (1 Torr)	CDG500T0001KF16	CDG500T0001VCR8
CDG-500 Capacitance Diaphragm Gauge (1000 Torr) with setpoints	CDG500T1000KF16S	CDG500T1000VCR8S
CDG-500 Capacitance Diaphragm Gauge (100 Torr) with setpoints	CDG500T0100KF16S	CDG500T0100VCR8S
CDG-500 Capacitance Diaphragm Gauge (10 Torr) with setpoints	CDG500T0010KF16S	CDG500T0010VCR8S
CDG-500 Capacitance Diaphragm Gauge (1 Torr) with setpoints	CDG500T0001KF16S	CDG500T0001VCR8S

## ACTIVE GAUGES

### ▶ Agilent PCG-750/PCG-752 Pirani/Capacitance Diaphragm Gauges



Profibus Version

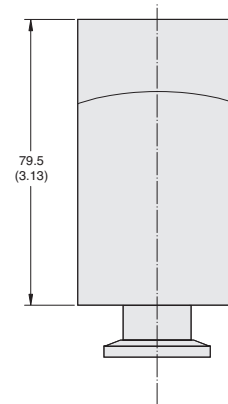
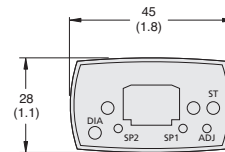

Dimensions: millimeters (inches)

The Agilent PCG-750 series of Pirani Capacitance Diaphragm gauges combines Agilent's Pirani and ceramic capacitance diaphragm sensors into a single design that provides gas-type independence with increased accuracy from Atm to  $5 \times 10^{-5}$  mbar ( $3.8 \times 10^{-5}$  Torr).

#### Applications

- Fore pressure vacuum monitoring
- Safety monitoring in vacuum systems
- General vacuum measurement and control in the medium and rough vacuum range
- Load lock control

#### Features

- High accuracy and reproducibility at atmosphere
- Fast atmospheric detection
- Gas-type independent above 10 mbar
- Compact, rugged housing that mounts in any orientation with a logarithmic signal output
- Set point control
- Exchangeable plug and play sensor
- Nickel filament option
- Bright color LCD display option

#### Benefits

- Reliable atmospheric pressure monitoring
- Shortens process cycle times
- Allows safe venting with any gas mixture
- Ease of integration
- Utilize pressure readings to perform critical operations
- Easy to repair with low cost of ownership
- Solution for corrosive applications
- Monitor pressure readings easily



# VACUUM MEASUREMENT

## Technical Specifications

<b>Measurement range</b> (Air, O <sub>2</sub> , CO, N <sub>2</sub> )	5 x 10 <sup>-5</sup> to 1500 mbar (3.8 x 10 <sup>-5</sup> to 1125 Torr)					
<b>Accuracy</b>	<b>% of reading</b>	<b>Units</b>				
	±50%	5 x 10 <sup>-5</sup> to 1 x 10 <sup>-3</sup> mbar (3.75 Torr to 1 x 10 <sup>-3</sup> Torr)				
	±15%	1 x 10 <sup>-3</sup> to 100 mbar (1 x 10 <sup>-3</sup> to 75 Torr)				
	±5%	100 to 950 mbar (75 to 712.5 Torr)				
	±2.5%	950 to 1050 mbar (712.5 to 787.5 Torr)				
<b>Repeatability</b> (N <sub>2</sub> )	<b>% of reading</b>	<b>Units</b>				
	±2.5%	1 x 10 <sup>-3</sup> to 1100 mbar (1 x 10 <sup>-3</sup> to 825 Torr)				
<b>Admissible pressure</b>	≤ 5 bar absolute					
<b>Burst pressure</b>	≤ 10 bar absolute					
<b>Admissible temperature</b>	<b>Operation</b> (ambient) 10 to 50 °C	<b>Storage</b> -20 to +65 °C			<b>Bakeout flange</b> ≤ 80 °C	
<b>Supply voltage</b>	15 to 30 VDC @ < 0.8 A					
<b>Output signal</b>	0 to 10.23 V					
<b>Measurement range</b>	0.61 to 10.23 V					
<b>Voltage vs. pressure</b>	1.286 V/decade					
<b>Load impedance</b>	> 10 kΩ					
<b>Setpoint relay</b> (2)	<b>Range</b> (N <sub>2</sub> )	<b>Relay</b> <b>Contact</b>	<b>Hysteresis</b>	<b>Contact Rating</b> <b>Solid state relays</b>	<b>Contact Rating</b> <b>Mechanical relays</b>	<b>Switching</b> <b>time</b>
	5 x 10 <sup>-5</sup> to 1500 mbar	n.o., potential free	10 % of threshold	≤30VDC/ ≤0.3ADC	≤30VDC/ ≤1ADC	≤30 ms
<b>Interface</b> (digital)	RS232C					
<b>Power connection</b>	FCC, 8 pin					
<b>Materials exposed to vacuum</b>	PCG-750: W, Ni, NiFe, Al <sub>2</sub> O <sub>3</sub> , SnAg, SS, glass PCG752: Ni, NiFe, Al <sub>2</sub> O <sub>3</sub> , SnAg, SS, glass					

## Ordering Information

Description	Part Number
PCG-750 Pirani/CDG combination gauge (tungsten), KF16	PCG750KF16
PCG-750 Pirani/CDG combination gauge (tungsten) with setpoints and display, KF16 (mbar)	PCG750KF16SD1
PCG-750 Pirani/CDG combination gauge (tungsten) with setpoints and display, KF16 (Torr)	PCG750KF16SD2
PCG-750 Pirani/CDG combination gauge (tungsten) with setpoints and display, KF16 (pascal)	PCG750KF16SD3
PCG-750 Pirani/CDG combination gauge (tungsten) with setpoints and Profibus, KF16 (mbar)	PCG750KF16SP
PCG-752 Pirani/CDG combination gauge (nickel), KF16	PCG752KF16
PCG-752 Pirani/CDG combination gauge (nickel) with setpoints and display, KF16 (mbar)	PCG752KF16SD1
PCG-752 Pirani/CDG combination gauge (nickel) with setpoints and display, KF16 (Torr)	PCG752KF16SD2
PCG-752 Pirani/CDG combination gauge (nickel) with setpoints and display, KF16 (pascal)	PCG752KF16SD3
PCG-752 Pirani/CDG combination gauge (nickel) with setpoints and Profibus, KF16 (mbar)	PCG752KF16SP
<b>Accessories</b>	
PCG-750 (tungsten) Replacement sensor –recommended for most applications	PCG750KF16RS
PCG-752 (nickel) Replacement sensor –recommended for corrosive applications	PCG752KF16RS

# ACTIVE GAUGES

## ▶ Agilent FRG-700/FRG-702 Full Range Pirani/Inverted Magnetron Gauges

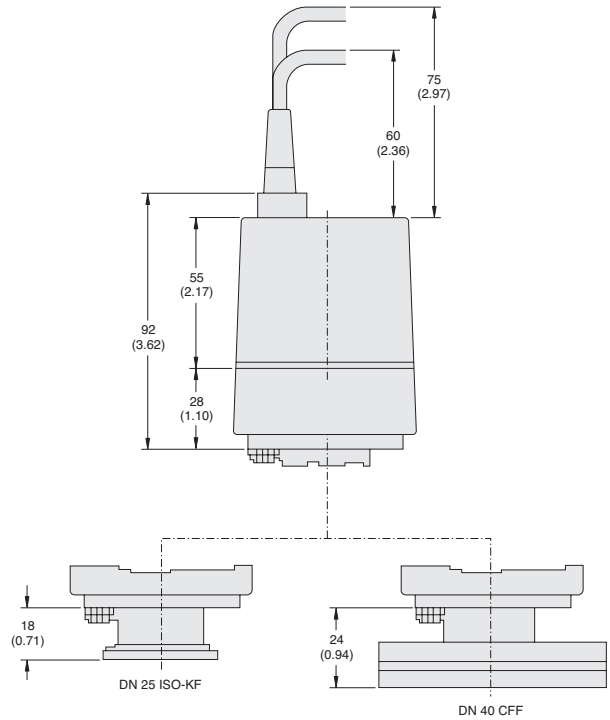

Dimensions: millimeters (inches)

The Agilent FRG-700 and FRG-702 (all metal version) are full range gauges that provide two measuring technologies in a single, compact and economical package to measure process and base pressure from  $5 \times 10^{-9}$  mbar to atmosphere ( $3.8 \times 10^{-9}$  Torr to atmosphere). The single, compact unit with one logarithmic analog output signal significantly reduces the complexity of installation, setup and integration. The benefit is reduced cost and reduction in valuable space requirements

### Applications

- High vacuum pressure monitoring
- Base pressure for evaporation and sputtering systems
- General vacuum measurement and control in the medium and high vacuum range

### Features

- Combination gauge – inverted magnetron and Pirani, with wide measurement range from  $5 \times 10^{-9}$  mbar to atmosphere
- No filament to burn out; easy to clean
- Excellent ignition properties
- Can be operated by a Agilent V-81 or V-301 rack controller and used with the TPS Compact and MiniTask
- LED indicator for high voltage on

### Benefits

- Measures 9 decades using 1 compact gauge, 1 connection, 1 sensor cable and 1 A/D converter; reduces complexity and cost
- Low maintenance and reduced cost
- Rapid start-up
- Greatly reduces cost and space requirements
- Provides quick visual indication of status

# VACUUM MEASUREMENT

## Technical Specifications

<b>Measurement range</b>	5 x 10 <sup>-9</sup> to 1000 mbar (3.8 x 10 <sup>-9</sup> to 760 Torr)			
<b>Accuracy</b>	±30% of reading, typical			
<b>Repeatability</b>	±5% of reading, typical			
<b>Mounting orientation</b>	Any			
<b>Admissible temperature</b>	<b>Operation</b> (ambient) 5 to 55 °C	<b>Storage</b> -40 to +65 °C	<b>Bake-out*</b> (w/o electronics) 150 °C	<b>Filament temperature</b> (Pirani) 120 °C
<b>Supply voltage</b>	<b>At gauge</b> 15 to 30 VDC		<b>Ripple</b> ≤1 V <sub>pp</sub>	<b>Power consumption</b> ≤2 W
<b>Output signal</b> (measurement signal)	<b>Voltage range</b> 0 to 10.5 V		<b>Measurement range</b> 1.82 to 8.6 V	
<b>Voltage vs. pressure</b>	0.6 V/decade, logarithmic			
<b>Error signal</b>	<0.5 V (no supply), >9.5 V (Pirani sensor, filament rupture)			
<b>Minimum loaded impedance</b>	10 kΩ, short-circuit proof			
<b>Response time</b>	<10 ms (@ p > 10 <sup>-6</sup> mbar), ≈1000 ms (@ p = 10 <sup>-8</sup> mbar)			
<b>Identification gauge</b>	85 kΩ, referenced to supply common			
<b>Status</b>	<b>Pirani-only mode</b> 0 V (low)	<b>Combined Pirani/cold cathode mode</b> 15 V to 30 (high)	<b>LED</b> LED green high voltage on	
<b>Electrical connection</b>	FCC 68 appliance connector, 8 poles, female			
<b>Sensor cable</b>	8 poles plus shielding			
<b>Maximum cable length</b>	≤50 m			
<b>Operating voltage/current</b>	≤3.3 kV/≤500 A			
<b>Materials exposed to vacuum</b>	<b>FRG-700</b> - SS, Al <sub>2</sub> O <sub>3</sub> , FPM75, Mo, Ni, Au, W		<b>FRG-702</b> - SS, Al <sub>2</sub> O <sub>3</sub> , FPM75, Mo, Ni, Au, W	
<b>Internal volume</b>	≈ 20 cm <sup>3</sup>			
<b>Weight</b>	<b>FRG-700</b> - DN 25 ISO-KF ≈700g, DN 40 CF ≈980 g <b>FRG-702</b> - DN 25 ISO-KF ≈730g, DN 40 CF ≈1010 g			
<b>Standards</b>	EN 61000-6-2, EN 61000-6-3, EN 61010-1			

\* Without electronics and magnetic shielding.

## Ordering Information

Description	Part Number
FRG-700 Pirani/IMG Combination Gauge, KF 25	FRG700KF25
FRG-700 Pirani/IMG Combination Gauge, DN40 CF	FRG700CF35
FRG-702 Pirani/IMG Combination Gauge, KF25, All Metal – bakeable	FRG702KF25
FRG-702 Pirani/IMG Combination Gauge, DN40 CF, All Metal – bakeable	FRG702CF35
<b>Accessories</b>	
FRG-700 Gauge Maintenance Kit	FRG700MAINT
FRG-700 Gauge Repair Kit	FRG700REPR
FRG-702 Gauge Maintenance Kit	FRG702MAINT
FRG-702 Gauge Repair Kit	FRG702REPR
FRG-700/702 Magnetic Shielding	FRG700MSHD
FRG-700 Cable, Gauge to AG Turbo Controller, 3M	9699960
FRG-700 Cable, Gauge to AG Turbo Controller, 5M	9699961

## ACTIVE GAUGES

### ▶ Agilent FRG-720/FRG-730 Full Range Pirani/Bayard-Alpert Gauges

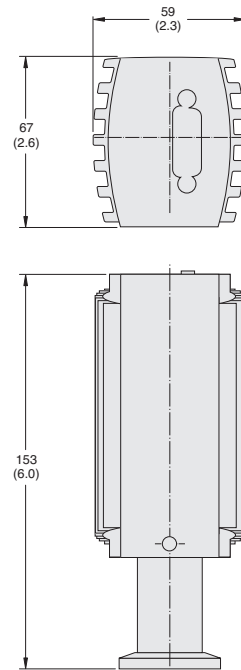

Dimensions: millimeters (inches)

The Agilent FRG-720 and FRG-730 combine Agilent's Pirani and Bayard-Alpert sensor into a single compact design that provides measuring capability from  $5 \times 10^{-10}$  mbar to atmosphere ( $3.8 \times 10^{-10}$  Torr to atmosphere). Combining these two technologies into a single unit reduces complexity and integration challenges while protecting the Bayard-Alpert sensor from premature burnout.

#### Applications

- Wide range from industrial coating and semiconductor processing to research and laboratory environments
- General vacuum measurement and control in the low to ultra-high vacuum range

#### Features

- Combination gauge – Bayard-Alpert and Pirani
- Pirani interlock
- Long-life yttrium oxide coated iridium filament
- Set point control
- LCD display option
- Profibus communication option

#### Benefits

- Wide measurement range from  $5 \times 10^{-10}$  mbar to atmosphere
- Protects Bayard-Alpert sensor from premature burnout and contamination effects from high pressure operation
- Rugged design for a wide range of applications
- Utilize pressure readings to perform critical operations
- Monitor pressure readings easily
- Ease of network integration

# VACUUM MEASUREMENT

## Technical Specifications

<b>Measurement range</b> (Air, O <sub>2</sub> , CO, N <sub>2</sub> )	5 x 10 <sup>-10</sup> to 1000 mbar (3.8 x 10 <sup>-10</sup> to 760 Torr)				
<b>Accuracy</b>	10 <sup>-8</sup> to 10 <sup>-2</sup> mbar/Torr – ±15% of reading				
<b>Repeatability</b>	10 <sup>-8</sup> to 10 <sup>-2</sup> mbar/Torr – ±5% of reading				
<b>Degas</b>	p < 7.2 x 10 <sup>-6</sup> mbar – electron bombardment, max. 3 min				
<b>Pressure, maximum</b>	2 bar absolute				
<b>Temperature</b>	<b>Operation</b> (ambient)	<b>Storage</b>	<b>Bakeout at flange</b> w/extension	<b>Bakeout at flange</b> wo/extension	<b>Bakeout w/electronics</b> removed
	0 to 50 °C	-20 to +70 °C	150 °C	80 °C	150 °C
<b>Supply voltage</b>	20 to 28 VDC, 1.4 A on startup for 200 msec, 0.8 A operating				
<b>Output signal analog</b>	0 to 10 V				
<b>Measurement range</b>	0.774 to 10.0 V				
<b>Voltage vs. pressure</b>	0.75 V/decade				
<b>Error signal</b>	0.3/0.5 V				
<b>Minimum loaded impedance</b>	10 kΩ				
<b>Communications interface</b>	RS-232C				
<b>Electrical connection</b>	D-sub, 15 pin, male				
<b>Maximum cable length</b>	100 m (330 ft)				
<b>Materials exposed to vacuum</b>	Yt <sub>2</sub> O <sub>3</sub> , Ir, Pt, Mo, Cu, W, NiFe, NiCr, stainless steel, glass				
<b>Internal volume</b>	KF/CF	24 cm <sup>3</sup> (1.46 in <sup>3</sup> )/34 cm <sup>3</sup> (2.1 in <sup>3</sup> )			
<b>Weight</b>	KF/CF	285 g/550 g			
<b>Protection type</b>	IP30				
<b>Setpoint relays (1) for FRG-730</b>	<b>Range</b>	<b>Relay Contact</b>	<b>Hysteresis</b>	<b>Contact rating</b>	
	1 x 10 <sup>-9</sup> to 100 mbar	n.o., potential free	10 % of reading	30 V/0.5 A DC	
<b>Profibus option</b>					
<b>Baud rates</b>	9.6/19.2/93.75/187.5/500 kBaud; 1.5/12 mBaud				
<b>Address</b>	2 switches (address 00 – 127) or network programmable				
<b>Digital functions</b>	Read pressure, select units (Torr, mbar, Pa); degas function, Pirani full scale adjust; monitor gauge status; safe state allows definition of behavior in case of error; detailed alarm and warning information				
<b>Analog functions</b>	0 to 10 V analog output pressure indication; two setpoint relays A + B				
<b>Setpoint relays (2)</b>	<b>Range</b>	<b>Relay Contact</b>	<b>Hysteresis</b>	<b>Contact rating</b>	
	1 x 10 <sup>-9</sup> to 100 mbar	n.o., potential free	10 % of reading	60 V/0.5 A DC	
<b>Connector for Profibus DP</b>	D-sub, 9 pin, female				

## Ordering Information

Description	Part Number	
	KF25	CF35
FRG-720 Pirani/Bayard Alpert combination gauge – single filament	FRG720KF25	FRG720CF35
with display	FRG720KF25D	FRG720CF35D
with setpoints and Profibus	FRG720KF25SP	FRG720CF35SP
FRG-730 Pirani/Bayard Alpert combination gauge – dual filaments w/set pts	FRG730KF25S	FRG730CF35S
FRG-730 Pirani/Bayard Alpert combination gauge – dual filaments w/set pts. and display	FRG730KF25SD	FRG730CF35SD
FRG-730 Pirani/Bayard Alpert combination gauge – dual filaments w/set pts and Profibus	FRG730KF25SP	FRG730CF35SP

### Accessories

FRG-720 Replacement sensor–KF25	FRG720KF25RS
FRG-720 Replacement sensor–CF35	FRG720CF35RS
FRG-730 (dual filaments)–KF25 Replacement sensor	FRG730KF25RS
FRG-730 (dual filaments)–CF35 Replacement sensor	FRG730CF35RS
FRG-720/730 Baffle	FRG720BFL
FRG-720/730 Power Supply 24 V DC/RS232C	FRG720PWR
FRG-720/730 Bakeout extension, 100mm	FRG720BKE

## ACTIVE GAUGES

### ▶ Agilent AGC-100 Active Gauge Controller/ AGD-100 Active Gauge Display

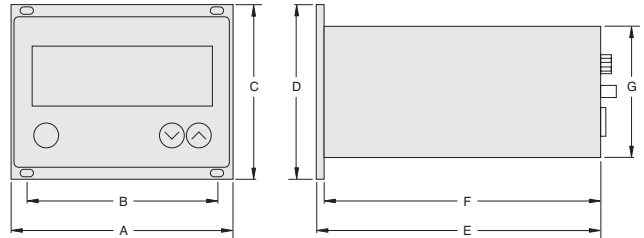

	A	B	C	D	E	F	G
<b>AGC-100</b>	106 (4.2)	91 (3.6)	78 (3.1)	84 (3.3)	210 (8.3)	207 (8.2)	67 (2.6)
<b>AGD-100</b>	106 (4.2)	91 (3.6)	78 (3.1)	84 (3.3)	136 (5.3)	132 (5.2)	62 (2.4)

*Dimensions: millimeters (inches)*

AGC-100 is single channel controller compatible with the FRG 7xx, PVG-5xx, PCG-75x and CDG-500 series of active gauges and automatically identifies the active gauge connected.

AGD-100 is a low cost single channel display option for the FRG-700/702, PVG-5xx and PCG-75x series of active gauges. Both units have user selectable measurement unit (mbar, Torr, Pascal), and adjustable setpoint control.

#### Features

- Automatic identification of Agilent active gauges
- User selectable pressure units (mbar, Torr, Pascal)
- Adjustable setpoint control

#### Benefits

- Ease of setup
- Global compatibility
- Utilize pressure readings to perform critical operations



# VACUUM MEASUREMENT

## Technical Specifications

<b>Measurement channels</b>	One (1)
<b>Measurement range</b>	$2 \times 10^{-10}$ to 1500 mbar ( $1.5 \times 10^{-10}$ to 1125 Torr)
<b>Measurement unit</b> (selectable)	mbar, Torr, Pascal
<b>Rate</b>	10/sec
<b>A/D converter</b>	16 bit
<b>Setpoints</b>	
<b>Setpoint relays</b>	One (1)
<b>Channel assignment</b>	One (1)
<b>Relay contact</b>	Potential free change over contact
<b>Hysteresis</b>	Adjustable
<b>Contact rating</b>	30 VAC/1A; 60 VDC/0.5A
<b>Connector</b>	D-Sub, 9 pin, male
<b>Display</b>	LED
<b>Analog output</b>	
<b>Range</b>	0-10.3 V, sensor analog output signal
<b>Connector</b>	D-Sub, 9 pin, male
<b>Supply</b>	90-250 V, 50/60 Hz
<b>Consumption</b>	#30W
<b>Operation temperature</b> (ambient)	5 to 50 °C
<b>Digital interface</b> (AGC-100 only)	RS-232C ; D-Sub, 9 pin, female

## Ordering Information

Description	Part Number
Active Gauge Controller for FRG 7xx, PVG-5xx, PCG-75x and CDG-500 Series	AGC100
Gauge display for FRG-700/702 and PVG-5xx and PCG-75x Series	AGD100

### Accessories

Front adapter for controller, rack adaptor, 3u	AGC100ADPT
Cable (FRG700/702, PVG, PCG) – 3 m (9.9 ft)	AGCCBL103
Cable (FRG700/702, PVG, PCG) – 5 m (16.4 ft)	AGCCBL105
Cable (FRG700/702, PVG, PCG) – 10 m (33 ft)	AGCCBL110
Cable (FRG720/730) – 3 m (9.9 ft)	AGCCBL203
Cable (FRG720/730) – 5 m (16.4 ft)	AGCCBL205
Cable (FRG720/730) – 10 m (33 ft)	AGCCBL210
Cable (CDG500) – 3 m (9.9 ft)	AGCCBL303
Cable (CDG500) – 5 m (16.4 ft)	AGCCBL305
Cable (CDG500) – 10 m (33 ft)	AGCCBL310

### Power Cord Selection One power cord included with each unit

Europe, 10 A/220-230 VAC, 2.5 meter	656494220
Denmark, 10 A/220-230 VAC, 2.5 meter	656494225
Switzerland, 10 A/230 VAC, 2.5 meter	656494235
UK/Ireland, 13 A/230 VAC, 2.5 meter	656494250
India, 10 A/220-250 VAC, 2.5 meter	656494245
Israel, 10 A/230 VAC, 2.5 meter	656494230
Japan, 12 A/100 VAC, 2.3 meter	656494240
North America, 13 A/125 VAC, 2.0 meter	656458203

# ACTIVE GAUGES

## ▶ Agilent RGC-100 Rough Gauge Controller

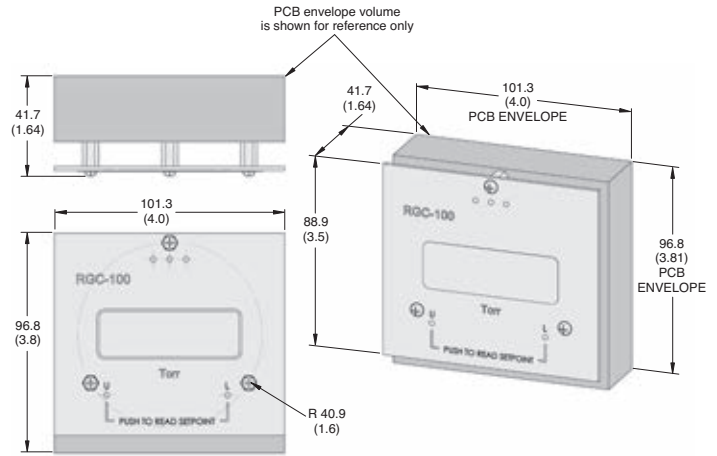

Dimensions: millimeters (inches)

The Agilent RGC-100 Rough Gauge Controller is a cost effective solution for pressure measurements in the  $1 \times 10^{-3}$  Torr to 760 Torr region.

The RGC-100 package includes the TC tube, sensor cable and power supply to provide a pre-calibrated turnkey rough vacuum solution.

### Applications

- General vacuum measurement and control in the rough vacuum range
- Monitor forelines, chamber evacuation and crossover to high vacuum pumps

### Features

- Thermocouple gauge – Agilent 531 – and controller are pre-calibrated as a set at the factory
- Runs on 100-230 VAC, 50/60 Hz and displays in Torr or mbar
- Large bright LED display
- No moving parts
- Optional set point control, analog output, RS232 communications
- Economical vacuum gauge

### Benefits

- No calibration required at initial setup
- Globally compatible
- Easily read from across a room, or in dimly lit locations
- Shock resistant and requires infrequent calibration
- Easily integrated
- Ideal choice for integrators

**NOTE** Factory calibration is performed using equipment under NIST Standards. Calibration certificates are not available with these products.

# VACUUM MEASUREMENT

## Technical Specifications

<b>Measurement range</b>	1.3 x 10 <sup>-3</sup> to 1000 mbar (1.0 x 10 <sup>-3</sup> to 760 Torr)	
<b>Accuracy</b>	<b>% of reading</b>	<b>Units</b>
	±10%	1.3 x 10 <sup>-3</sup> to 1.3 mbar (1 milliTorr to 1 Torr)
	±15%	1.3 to 13.3 mbar (1 to 10 Torr)
	±50%	13.3 to 213 mbar (10 to 160 Torr)
	±25%	213 to 1000 mbar (160 Torr to 760 Torr)
<b>Vacuum fitting</b>	½ inch NPT-M	
<b>Interface cable length</b>	10 ft.	
<b>Sensor</b>	Agilent 531 TC gauge tube	
<b>Display</b>	See below	
<b>Dimensions</b>	Mounts in 2.66 inch panel hole with 3 screws on 1.60 inch radius	
<b>Supply voltage</b>	100-240 VAC, 50/60 Hz	
<b>Standards</b>	CE, ROHS compliant	
<b>Optional setpoint controls</b>	7 A, 250 V	
<b>Optional communication interface</b>	RS-232	
<b>Optional analog output</b>	0-5 VDC	

## Ordering Information

Description	Part Number
RGC-100 Rough Gauge Controller (mbar)	RGC100M
RGC-100 Rough Gauge Controller (Torr)	RGC100T
RGC-100 Rough Gauge Controller with setpoints and RS232 (mbar)	RGC100MS
RGC-100 Rough Gauge Controller with setpoints and RS232 (Torr)	RGC100TS
RGC-100, 1.33" CFF TC, mbar, Controller	RGC100MCF
RGC-100, KF16 536 TC, mbar, Controller	RGC100MKF16
RGC-100, KF25 536 TC, mbar, Controller	RGC100MKF25
RGC-100, 1.33" CFF TC, mbar, SPs, Controller	RGC100MSCF
RGC-100, KF16 536 TC, mbar, SPs, Controller	RGC100MSKF16
RGC-100, KF25 536 TC, mbar, SPs, Controller	RGC100MSKF25
RGC-100, 1.33" CFF TC, Torr, Controller	RGC100TCF
RGC-100, KF16 536 TC, Torr, Controller	RGC100TKF16
RGC-100, KF25 536 TC, Torr, Controller	RGC100TKF25
RGC-100, 1.33" CFF TC, Torr, SPs, Controller	RGC100TSCF
RGC-100, KF16 536 TC, Torr, SPs, Controller	RGC100TSKF16
RGC-100, KF25 536 TC, Torr, SPs, Controller	RGC100TSKF25

### Accessories

Replacement sensors	
½ inch NPT-M	F0472303
KF16	L6141308
KF25	L6141309
1.33 in CFF	L6141304

**NOTE** All part number with "S" include the optional set points, RS232, and analog output.

# ACTIVE GAUGES

## ▶ Agilent RGC-150 Rough Gauge Controller

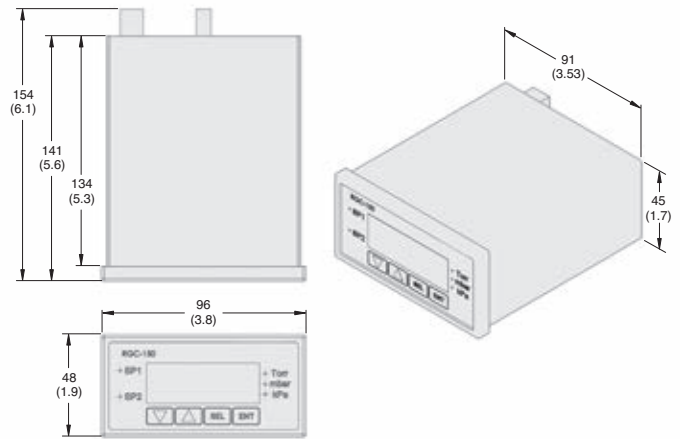

Dimensions: millimeters (inches)

The Agilent RGC-150 Rough Gauge Controller is a cost effective solution for pressure measurements in the  $1 \times 10^{-3}$  Torr to 760 Torr region.

The RGC-150 package includes the TC tube, sensor cable and power supply to provide a pre-calibrated turnkey rough vacuum solution.

### Applications

- General vacuum measurement and control in the rough vacuum range
- Monitor forelines, chamber evacuation and crossover to high vacuum pumps

### Features

- Thermocouple gauge – Agilent 531 – and controller are pre-calibrated as a set at the factory
- Two easily configured set points
- Runs on 100-230 VAC, 50/60 Hz and displays in Torr, mbar and kPa
- Large bright LED display
- Optional Ethernet connection and software that allows for remote monitoring through a web browser

### Benefits

- No calibration required at initial setup
- Utilize pressure readings to perform critical operations
- Globally compatible
- Easily read from across a room or in dimly lit locations
- Monitor vacuum performance from a remote location

**NOTE** Factory calibration is performed using equipment under NIST Standards. Calibration certificates are not available with these products.

# VACUUM MEASUREMENT

## Technical Specifications

<b>Measurement range</b>	1.3 x 10 <sup>-3</sup> to 1000 mbar (1.0 x 10 <sup>-3</sup> to 760 Torr)	
<b>Accuracy</b>	<b>% of reading</b>	<b>Units</b>
	±10%	1.3 x 10 <sup>-3</sup> to 1.3 mbar (1 milliTorr to 1 Torr)
	±15%	1.3 to 13.3 mbar (1 to 10 Torr)
	±50%	13.3 to 213 mbar (10 to 160 Torr)
	±25%	213 to 1000 mbar (160 Torr to 760 Torr)
<b>Vacuum fitting</b>	½ inch NPT-M	
<b>Interface cable length</b>	10 ft.	
<b>Sensor</b>	See below	
<b>Display</b>	0.38 inch high 6 digit red LED	
<b>Dimensions</b>	1.7 inch high, 3.52 inch wide, 5.35 inch deep	
<b>Analog output</b>	0-5 VDC	
<b>Supply voltage</b>	100-240 VAC, 50/60 Hz	
<b>Standards</b>	CE, ROHS compliant	
<b>Set point controls</b>	7 A, 250 V	
<b>Communication interface</b>	RS-232	
<b>Mounting</b>	½ DIN rack mount	

## Ordering Information

Description	Part Number
RGC-150 Rough Gauge Controller	RGC150
RGC-150 Rough Gauge Controller with Ethernet and Software	RGC150E
RGC-150, 1.33" CFF TC, Rough Vac Controller	RGC150CF
RGC-150, KF16 536TC, Rough Vac Controller	RGC150KF16
RGC-150, KF25 536TC, Rough Vac Controller	RGC150KF25
RGC-150, 1.33" CFF TC, Rough Vac Controller, Ethernet	RGC150ECF
RGC-150, KF16 536TC, Rough Vac Controller, Ethernet	RGC150EKF16
RGC-150, KF25 536TC, Rough Vac Controller, Ethernet	RGC150EKF25

### Accessories

Replacement sensors	
½ inch NPT-M	F0472303
KF16	L6141308
KF25	L6141309
1.33 in CFF	L6141305

**NOTE** All units include set points, RS232 and analog output.

# GAUGE CABLES

**NOTE** All cables are available in 5 foot increments.

## Ordering Information

Description	Length (in feet)	Part Number	Shipping Weight kg (lbs)
<b>XGS-600</b> I/O, with flying leads	10	R32493010	2.0 (1.0)
	25	R32493025	2.0 (1.0)
	50	R32493050	3.0 (1.5)
<b>Thermocouple Cables</b> ( <i>XGS-600 and senTorr only</i> ) For use with one 531 or 536 gauge tubes	10	L91313010	2.0 (1.0)
	25	L91313025	2.0 (1.0)
	50	L91313050	3.0 (1.5)
	75	L91313075	
	100	L91313100	
<b>ConvecTorr Cables</b> ( <i>XGS-600, Multi-Gauge, senTorr and PanelVac ConvecTorr</i> ) Standard non-bakeable	10	L91223010	2.0 (1.0)
	25	L91223025	2.0 (1.0)
	50	L91223050	3.0 (1.5)
	100	L91223100	
<b>Thermocouple Cables</b> ( <i>Multi-Gauge only</i> ) Dual (for use with two gauges) Dual (for use with two gauges) Quad (for use with four gauges) Quad (for use with four gauges)	10	L64752010	2.0 (1.0)
	25	L64752025	2.0 (1.0)
	10	L64754010	2.0 (1.0)
	25	L64754025	2.0 (1.0)
<b>Glass BA Gauge Cables</b> Standard non-bakeable	10	R32443010	2.0 (1.0)
	25	R32443025	2.0 (1.0)
	100	R32443050	2.0 (1.0)
<b>MBA2-200 Gauge Cables</b>	10	X320360006	2.0 (1.0)
	25	X320360007	2.0 (1.0)
	50	X320360008	3.0 (1.5)
	65	X320360009	3.0 (1.5)
	75	X320360010	3.0 (1.5)
<b>UHV-24/UHV-24p Standard</b> Standard non-bakeable	10	R32453010	2.0 (1.0)
	25	R32453025	2.0 (1.0)
	50	R32453050	3.0 (1.5)
<b>UHV-24/UHV-24p PTFE (for UHV)</b> bakeable to 250 °C	10	R32463010	2.0 (1.0)
	25	R32463025	2.0 (1.0)
	50	R32463050	3.0 (1.5)
<b>Ion Gauge Extension Cables</b> ( <i>XGS-600</i> )	65	R3247065	
	90	R3247090	



# VACUUM MEASUREMENT

## Ordering Information

Description	Length (in feet)	Part Number	Shipping Weight kg (lbs)	
<b>IMG-100 Cables</b> ( <i>XGS-600</i> ) Standard non-bakeable may be used with IMG-300	10	R03113010	2.0 (1.0)	
	25	R03113025	2.0 (1.0)	
	50	R03113080	3.0 (1.5)	
	75	R03113075		
	100	R03113100		
<b>IMG-300 Cables</b> Inverted Magnetron Gauge ( <i>UHV</i> ) Bakeable to 250 °C	10	R03413010	2.0 (1.0)	
	25	R03413025	2.0 (1.0)	
	65	R03413065		
	100	R03413100		
<b>FRG-700 Cables</b> Gauge to FRG Controller Gauge to FRG Controller Gauge to AG Turbo Controller	3 m	AGCCBL103		
	5 m	AGCCBL105		
	3 m	9699960		
	5 m	9699961		
<b>XGS-600 Analog Board Cables</b>		<b>Part Number</b>		
<b>Cable Length</b>	<b>3 ft</b>	<b>10 ft</b>	<b>25 ft</b>	<b>50 ft</b>
FRG-700/PVG/PCG Analog Input Board	R35893003	R35893010	R35893025	R35893050
CDG Analog Input Board	R35903003	R35903010	R35903025	R35903050
FRG720/730 Analog Input Board	R35913003	R35913010	R35913025	R35913050

## Vacuum Gauge Technical Notes

### Historical Notes

Early interest in pressure measurement was stimulated in the 17th century by engineers who were concerned about the inability of suction pumps to remove water from mines. The pumps were limited to about 30 feet. For example, the Duke of Tuscany (Italy) commissioned Galileo to investigate the problem.

Galileo, among others, devised a number of experiments to investigate the properties of air. Among these experiments were pistons for measuring the “force of vacuum” and a water barometer that stood about 34 feet tall.

After Galileo’s death in 1642, the work was carried on by his associate, Evangelista Torricelli. Torricelli invented the mercury barometer (Figure 1) and he concluded that atmospheric air forced water up to a height of 33.6 feet.

**Figure 1 - Mercury Barometer**

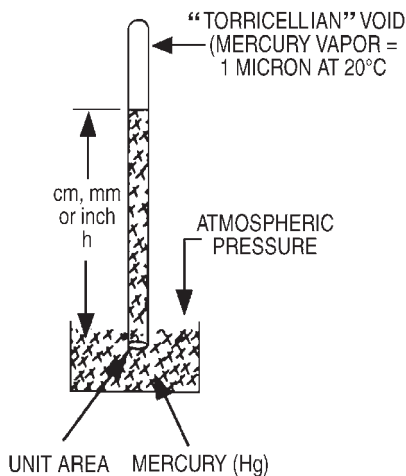

### Figure 1 Notes

- Air has weight...mass
  - 2 lbs per cubic yard, or
  - 1.293 grams per liter
- Pressure = force per unit area
- The Barometer – At “standard conditions”, the height of the Hg in the column above the surface of the Hg in the dish will be 760 mm or 29.9 in. The density of mercury is 0.49 lbs per cubic inch and, if the column is 29.9 in. high, it would then exert a force per unit area of  $0.49 \times 29.9 = 14.7$  pounds/in<sup>2</sup>.

The weight of the atmosphere exerts a force of 14.7 pounds per square inch on the surface of the Hg in the dish. The height of the mercury column is therefore a direct measure of the pressure and the unit of pressure is 1/760 of an atmosphere, which is called a Torr. The international pressure unit is Pascal, equal to one Newton per meter square.

In 1644, the French mathematician, Blaise Pascal, sent a group of mountaineers up into the Alps with a barometer and proved that air pressure decreased with altitude. The average height of the mercury column at sea level is 760 mm, and this

is defined as a standard atmosphere.

This also is  $1.01 \times 10^5$  Pascals or  $1.01 \times 10^5$  dynes cm<sup>2</sup>. The 1/760 of this value is called a Torr in honor of Torricelli.

An extension of the mercury barometer was the mercury U-tube manometer (Figure 2). Varying atmospheric pressures causes the mercury level to rise and fall in the “Torricellian Void.” Likewise, if the pressure at the other end of the tube is artificially reduced by a vacuum pump, the mercury in the tube falls drastically.

With both the barometer and the manometer, it is the difference in heights of the mercury levels that indicates the pressure, that is, the force (weight of Hg) per unit area that the air pressure will support. As the pressure on the system side is reduced, the height of the columns on either side of the U-tube approaches the same, and any difference becomes very difficult to measure (Figure 2).

**Figure 2 - U-Tube Manometer**

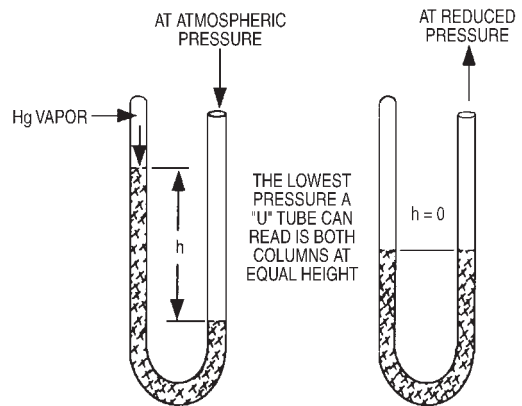

Many schemes were tried to magnify the very small differences that occurred at very low pressures, but the only one that really extended the range of the manometer was invented by H. McLeod in 1872. This gauge is an application of Boyle’s Law and is still in use today as a standard for calibrating secondary gauges (Figure 3).

**Figure 3 - McLeod Gauge**

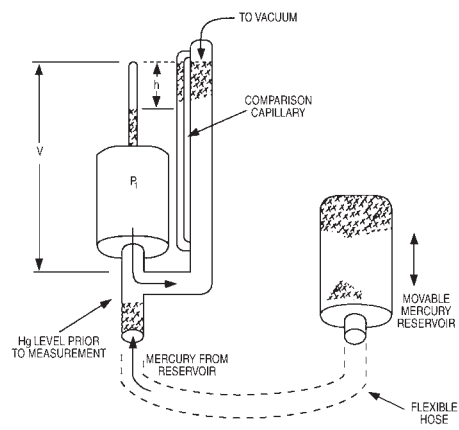

# VACUUM MEASUREMENT

## Application of Boyle's Law

$$\begin{aligned}
 P_2 &= V_2 \\
 (P_1 + h) bh &= P_1 V_1 \\
 P_1 bh + bh^2 &= P_1 V_1 \\
 bh^2 &= P_1 V_1 - P_1 bh \\
 bh^2 &= P_1 (V_1 - bh) \\
 P_1 &= \frac{bh^2}{V_1 - bh} \\
 &= \frac{bh^2}{V_1}
 \end{aligned}$$

$V_1$  = Total volume, capillary plus bulb ( $\text{cm}^3$ )

$P_1$  = Pressure in system

$b$  = Volum of capillary (in cubic cm)  
mm length

$h$  = Difference in height of mercury columns

$V_2 = bh$  ( $\text{cm}^3$ ) volume in capillary

Figure 4 - Pressure Ranges of Various Vacuum Gauges

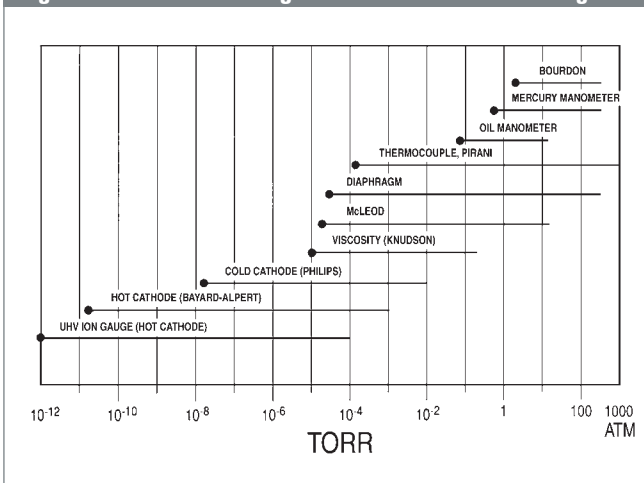

## Applications

The vacuum gauges in use today mainly fall into three categories: mechanical, manometric, and electronic. Which gauge is used in a particular application generally depends on the pressure range it is intended to measure. Figure 4 shows useful pressure ranges of some typical gauges.

High pressures, such as those found in the rough pumping of a vacuum system, are generally measured with a thermocouple gauge. This instrument measures heat transfer rate from a heated wire. As gas is removed from the system, less heat is removed. The changes in temperature are measured by a thermocouple junction and its output is displayed as changes in pressure. The most useful pressure range for this gauge is from 5 Torr to 5 microns.

At lower pressures – from  $1 \times 10^{-2}$  Torr to  $1 \times 10^{-7}$  Torr – found in many industrial applications, the cold cathode gauge is very useful. This instrument is basically a gaseous electric discharge cell which operates on the same principle as a diode-type ion pump. It is a rugged gauge that does not use a hot filament.

The most commonly used measurement device for high vacuum is the hot filament ionization gauge. This type of gauge can be designed to measure pressures as high as  $5 \times 10^{-1}$  Torr, and as low as  $5 \times 10^{-12}$  Torr. Since it is found in many industrial and scientific applications, it will be treated here in more detail.

## Basic Performance Factors of Ionization Gauges

- 1. Reproducibility.** A gauge must be able to give reproducible readings for identical physical situations. Drift due to electric or geometric instabilities can have adverse effects on the measurement process.
- 2. Accuracy.** Gauges can be calibrated but, in general, their accuracy is limited to about  $\pm 20\%$ .
- 3. Sensitivity.** In the ion gauge, the positive ions that impact the collector (and pick up electrons from ground) account for the positive ion current ( $I^+$ ).

The electrons emitted from the filament ( $I^-$ ) produce the required ionization. The fundamental relationship is:

$$I^+ = (I^-)^{PK} \quad (1)$$

**Where:** ( $P$ ) is the number of molecules present (Pressure)

**And:** ( $K$ ) is the gauge constant which depends on the geometry of the device and the electrical parameters employed ( $K$ ) is also referred to as the sensitivity ( $S$ ), and:

$$S = \frac{I^+}{P \cdot I^-}$$

**Where:** Both ( $I^+$ ) and ( $I^-$ ) are measured in amperes and ( $P$ ) is in Torr.

$$\text{Hence:} \quad S = \frac{(I^+) \text{ Amps}}{(I^-) \text{ Amps Torr}} = (\text{a number}) \text{ torr}$$

For instance, the sensitivity of the Agilent UHV-24 nude gauge is 25 per Torr.

# AGILENT TECHNICAL NOTES

## Operation of Ionization Gauges

Table 1 - Conversion Table						
	Pascal (N/m <sup>2</sup> ) (Pa)	Torr	Standard Atmosphere (atm)	Millibar (mbar)	Dyne per Square Centimeter (dyne/cm <sup>2</sup> )	
<b>1 Newton per square meter</b> (N/m <sup>2</sup> ) = Pascal	= 1	7.5 x 10 <sup>-3</sup>	9.87 x 10 <sup>-6</sup>	10 <sup>-2</sup>	10	
<b>1 Torr = 1 mm Hg</b>	= 133	1	1.32 x 10 <sup>-3</sup>	1.33	1,330	
<b>1 standard atmosphere (atm)</b>	= 101,000	760	1	1,010	1,010,000	
<b>1 millibar (mbar)</b>	= 100	0.75	9.87 x 10 <sup>-6</sup>	1	1,000	
<b>1 dyne/square centimeter</b> (dyne/cm <sup>2</sup> )	= 10 <sup>-1</sup>	7.5 x 10 <sup>-4</sup>	9.87 x 10 <sup>-7</sup>	x 10 <sup>-3</sup>	1	

When an ionization gauge is used to measure pressure, two physically observable parameters are of interest; namely, emission current and ion current. These two currents must be observed simultaneously, and the pressure can be calculated by the following rule:

$$P = \frac{(I^+) 1}{(I^-) S}$$

- I<sup>+</sup> = Observed ion current
- I<sup>-</sup> = Observed emission current
- S = Gauge sensitivity (constant for any particular gauge)

Although the McLeod gauge uses mercury in a way different from the manometer, it still expresses pressure in terms of the height of a mercury column. At the pressures attained by modern vacuum systems, gauges that depend on the mechanical effects of pressure are ineffective. So, other means had to be found that could take advantage of other properties of atoms and molecules, such as heat conductivity or the ability to be ionized.

There are many ways to express pressure and some of the more common units are listed in Table 1.

The gauge sensitivity, S, is a function of the design and construction of the gauge. For the Agilent 563 Bayard-Alpert gauge, S has a nominal value of 10 Torr. For the Agilent 507 Triode gauge, S has a nominal value of 17 Torr.

One could use an instrument that measured both the I<sup>+</sup> and I<sup>-</sup> currents with a high degree of accuracy. However, the absolute values of I<sup>+</sup> and I<sup>-</sup> are unimportant in determining P; only their ratio must be measured. Therefore, entirely equivalent results can be obtained with an instrument which measures I<sup>+</sup> as a fraction of I<sup>-</sup> (a ratiometric instrument).

Table 2 - Pressure and Flow Unit	
<b>Pressures</b>	
Standard atm	= 1.01325 x 10 <sup>6</sup> Dynes cm <sup>-2</sup> = 760 mm Hg (at 0 °C) = 29.9213 in. of Hg (at 32 °F)
Bar	= 1 x 10 <sup>6</sup> Dynes cm <sup>-2</sup> 75.0062 cm Hg (at 0 °C) 0.986 atm
Torr	= 1333 Dynes cm <sup>-2</sup> = 1 mm Hg (at 0 °C) = (760) <sup>-1</sup> Standard atm
Micron	= (length) 1000 Angstroms (1A = 10 <sup>-10</sup> meter) = (pressure) 1.33 Dyne cm <sup>-2</sup> = (pressure) 1 x 10 <sup>-3</sup> Torr
Barye	= 1 Dyne cm <sup>-2</sup> = 9.869 x 10 <sup>-7</sup> atm = 1 x 10 <sup>-6</sup> bar
Dyne	= Force necessary to give a one-gram mass an acceleration of one cm/sec/sec
<b>Flows</b>	
Cubic Foot	= 28.3 liters = 2.83 x 10 <sup>4</sup> cm <sup>3</sup>
CFM	= 28.3 liters min <sup>-1</sup> = 0.47 liter sec <sup>-1</sup>
Liter sec <sup>-1</sup>	= 2.12 cfm = 3.53 x 10 <sup>-2</sup> cubic feet sec <sup>-1</sup>

# VACUUM MEASUREMENT

It is convenient to maintain a constant emission current at a preselected value rather than to observe it for each measurement of pressure. Thus, in some gauge controls, the emission current is regulated at a nominal value of 9 ma (Bayard-Alpert) or 6 ma (triode). This value of emission leads to ion currents equal to 0.1 amp/Torr. During the calibration procedure, emission current is sensed by the electrometer amplifier and displayed on the panel meter. When the ion current is measured, the same amplifier and meter are used. Hence, the meter deflection observed during ion current measurement is automatically interpreted as a fraction of emission current, providing a true ratiometric measurement, even though the absolute value of emission current may be 20% different from nominal.

In conventional gauge controls, emission current is measured by the panel meter with suitable precision resistor shunts. The ion current is then amplified by an electrometer and displayed on the meter. Overall accuracy of this kind of system depends on the individual accuracies of the shunt resistors, the meter movement, and the electrometer gain. Since these items all function independently, the errors can add up.

However, in the Agilent ionization gauge controls, the electrometer and meter are always used together, whether measuring emission or ion currents. Thus, some of the errors are cancelled in the calibration process. As a result, the accuracy of the Agilent controls is not critically dependent on

the tolerances of a large number of components, and long-term accuracy and repeatability are assured.

Some additional conversion factors for pressure and flow units are shown in Table 2.

## **Cold Cathode Gauges**

The cold cathode gauge is an often overlooked, cost-effective gauge for ion implanters and other high-vacuum applications. A cold cathode gauge has no filament, is not subject to burnout and has a significantly longer life and lower annual replacement cost than a hot cathode Bayard-Alpert gauge. A cold-cathode gauge can be replaced at predictable intervals, whereas a hot cathode gauge must be replaced whenever a burnout occurs. In addition, the annual cost of replacement is less. A modern inverted magnetron cold cathode gauge is stable and can operate over a wide pressure range from 10 mTorr down to ultra-high vacuum. Repeatability is better than 98%. Cold cathode gauges have a reputation as 'slow starters,' since they must rely on an ionization source such as a cosmic ray to initiate a discharge. The lower the pressure, the less likely an ionizing collision and the longer the start delay. At 1 mTorr or higher, there is no delay; but at  $10^{-8}$  Torr, starting can take up to 3 hours. The traditional solution is to start the gauge in the mTorr range, but often this is not practical. A relatively new technique uses ultraviolet induced photoemission to generate an ionizing electron to start the gauge.<sup>8</sup> At  $10^{-6}$  Torr the start time is 4-5 seconds.

# Agilent HGC-536 Portable Vacuum Gauge

## Handheld Thermocouple Gauge Controller

The HGC-536 is a rugged, portable vacuum gauge designed for those who need to quickly identify problems in the field. It features a long battery life, durable cover, and powerful magnet for hands-free use.



## Specifications

Parameter	Specification
Part number	X3001-60536
Power	Four AA batteries or Micro-B USB
Sensor	Agilent 536 Thermocouple Gauge Tube
Vacuum interface	KF25
Units	Torr, microns, mbar, bar, kPa, inches of Hg, mm Hg, millitorr, inches of water, PSIA, Pa
Accuracy	1~99 millitorr $\pm 2$ millitorr or 20 % 100~2,000 millitorr $\pm 10$ % 2~6 torr $\pm 25$ % 6~800 torr continuous and monotonic
Range	1 mT–800 torr
Mount	Portable handheld
Display	Graphical
Product dimensions	6.2" $\times$ 3.7" $\times$ 1.3"
Wetted materials	304L Stainless steel, glass, Type P thermocouple



## Features

- Rugged design for field use
- 70 hour battery life
- Provides pump down graphics

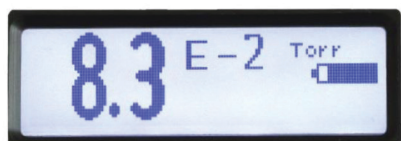

## HGC-536 Portable

- **Helps baseline pumps:** Provides an accurate reading of the pressure at which the pump is holding so it can be pumped down and stabilized at the appropriate pressure, if necessary.
- **Graphs readings:** Will collect vacuum readings over a period of time and graph them, providing a full view of pump performance.
- **Schlenk lines performance:** The HGC Portable can display the residual pressure in a schlenk line following an evacuation.
- **Schlenk line baseline:** Before an evacuation, the HGC can deliver a baseline reading that can be used for data compilation afterwards.
- **Publication grade research:** In addition to the data collection features, the multiple units of measurement allow for full research studies suitable for publication.

## Additional features

Feature	Description
Numeric and graphical displays	See your vacuum readings in either numbers or easy to read graphs.
Bluetooth capabilities	View pressure readings on your smartphone with the app.
Digital graphics	Easily view line graphs and time horizons of 2 minutes and 2 hours.
7-foot sensor cable length	Long cable length for portability and field use

## RGC-100T Gauge Controller



The Agilent RGC-100T is a rough vacuum gauge controller for pressure measurement in the  $1 \times 10^{-3}$  to 760 Torr ( $1 \times 10^{-3}$  to  $10^{13}$  mbar) range.

This gauge controller is made radiation-resistant using radiation-hardened components, and it will operate the 531 and 536 thermocouples.

- This controller is a compatible replacement to the 801 Thermocouple Gauge Controller.
- Target applications include high energy physics, linear accelerators, and other high-radiation environments in the rough.

Technical Specifications	
Measurement Range	$1 \times 10^{-3}$ to 1,000 mbar ( $1 \times 10^{-3}$ to 760 Torr)
Accuracy % of Reading	$\pm 10\%$ $1.3 \times 10^{-3}$ to 1.3 mbar (1 mTorr to 1 Torr) $\pm 15\%$ 1.3 to 13.3 mbar (1 to 10 Torr) $\pm 50\%$ 13.3 to 213 mbar (10 to 160 Torr) $\pm 25\%$ 213 to 1,000 mbar (160 Torr to 760 Torr)
Calibration	Factory-calibrated with Agilent 536 TC gauge tube (to be ordered separately)
Analog Output	$\emptyset$ - 11 mV
Supply Voltage	125 VAC, 50/60 Hz
Mounting	Mounts in 2.66 inch panel hole with 3 screws on 1.60 inch radius
Standards	CE, ROHS

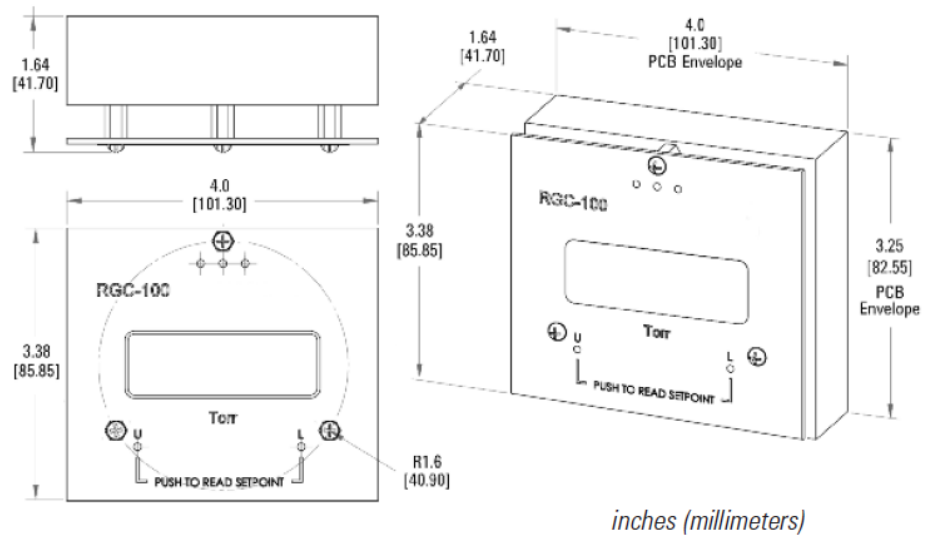

Ordering Information	Part Number
RGC-100T Digital Gauge OEM Version (with power cord)	X3001-60001
Thermocouple cable 4 ft 6 in long	X3001-60002
Thermocouple cable 7 ft 10 in long	X3001-60003

For more information, please contact your Agilent representative or visit [RGC-100T Radiation Resistant Rough-Vacuum Gauge Controller](#), where you can chat with a product expert.

You may be also interested in: [531 Thermocouple](#) and [536 Thermocouple](#)

**По вопросам продаж и поддержки обращайтесь:**

Алматы (7273)495-231	Казань (843)206-01-48	Новокузнецк (3843)20-46-81	Смоленск (4812)29-41-54
Архангельск (8182)63-90-72	Калининград (4012)72-03-81	Новосибирск (383)227-86-73	Сочи (862)225-72-31
Астрахань (8512)99-46-04	Калуга (4842)92-23-67	Омск (3812)21-46-40	Ставрополь (8652)20-65-13
Барнаул (3852)73-04-60	Кемерово (3842)65-04-62	Орел (4862)44-53-42	Сургут (3462)77-98-35
Белгород (4722)40-23-64	Киров (8332)68-02-04	Оренбург (3532)37-68-04	Тверь (4822)63-31-35
Брянск (4832)59-03-52	Краснодар (861)203-40-90	Пенза (8412)22-31-16	Томск (3822)98-41-53
Владивосток (423)249-28-31	Красноярск (391)204-63-61	Пермь (342)205-81-47	Тула (4872)74-02-29
Волгоград (844)278-03-48	Курск (4712)77-13-04	Ростов-на-Дону (863)308-18-15	Тюмень (3452)66-21-18
Вологда (8172)26-41-59	Липецк (4742)52-20-81	Рязань (4912)46-61-64	Ульяновск (8422)24-23-59
Воронеж (473)204-51-73	Магнитогорск (3519)55-03-13	Самара (846)206-03-16	Уфа (347)229-48-12
Екатеринбург (343)384-55-89	Москва (495)268-04-70	Санкт-Петербург (812)309-46-40	Хабаровск (4212)92-98-04
Иваново (4932)77-34-06	Мурманск (8152)59-64-93	Саратов (845)249-38-78	Челябинск (351)202-03-61
Ижевск (3412)26-03-58	Набережные Челны (8552)20-53-41	Севастополь (8692)22-31-93	Череповец (8202)49-02-64
Иркутск (395)279-98-46	Нижний Новгород (831)429-08-12	Симферополь (3652)67-13-56	Ярославль (4852)69-52-93
Россия (495)268-04-70	Киргизия (996)312-96-26-47	Казахстан (7172)727-132	

[afr@nt-rt.ru](mailto:afr@nt-rt.ru) || <https://agilent.nt-rt.ru/>